

Power is our commodity, the world is our market !

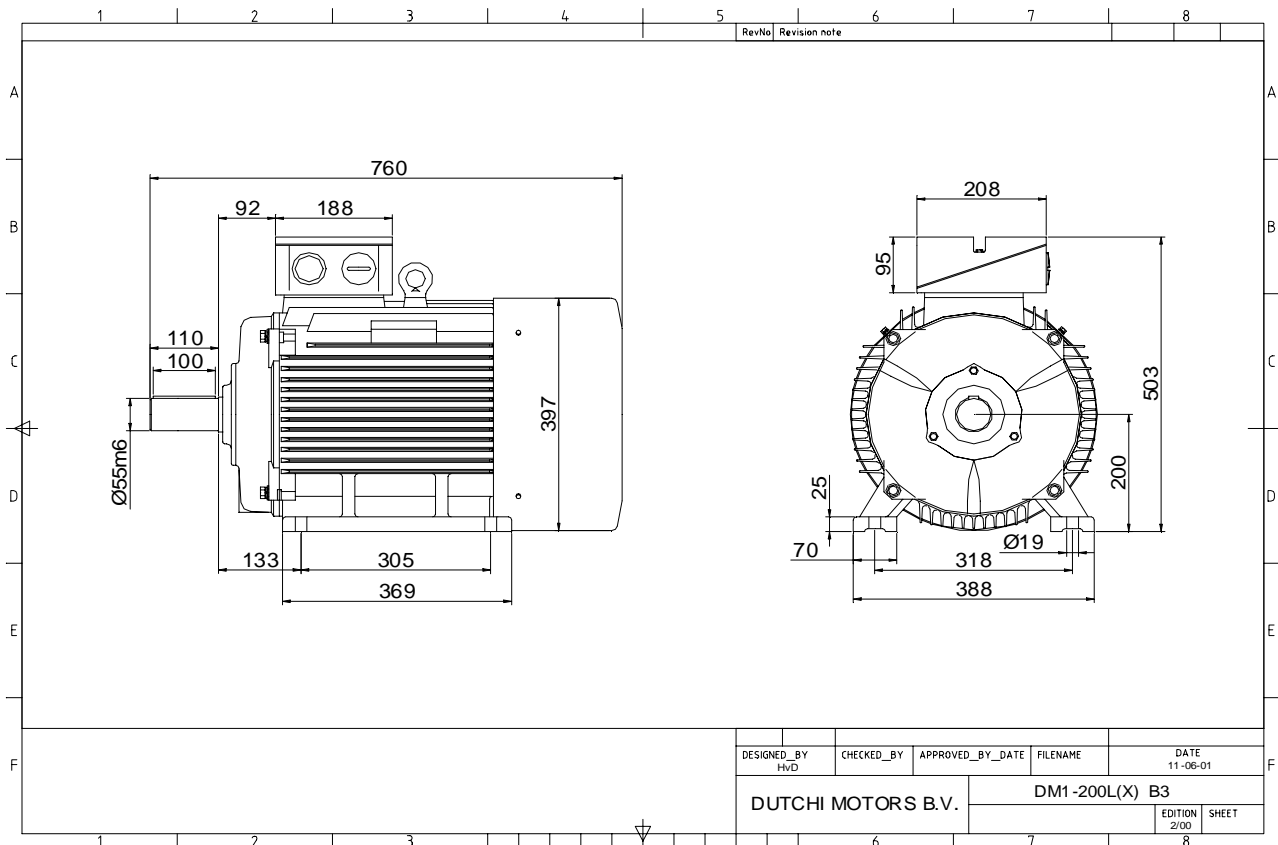

Specification **IEC 60034-1**
 Manufacturer **Dutchi Motors B.V.**
 Motor type **DM1- 200 L8**
 Rated power **15** kW **S1** duty
 Speed **730** r.p.m
 Voltage **400 / 690** V
 Frequency **50** Hz
 Connection **Δ / Y**
 Amps full load **32,4 / 18,7** A
 Amps no-load(400V) **17,80** A
 Enclosure **IP 55**
 Insulation Class **F (temp. rise B (80 K))**

Max. coolant temp. **40°C**
 Max. altitude **1.000** mtr, above sea level
 Comment **3 x PTC 150°C**
 Cable entries **2 x M50x1,5 + 1 x M20x1,5 (ptc)**

Feature **Cast-iron motor**
 Weight **230** kg
 Catalog no. **11138A15D**
 Warranty **12~18 months**

Efficiency class **N/A**
 Load data 100% 75% 50% 25%
 Efficiency **89,3 89,3 87,7 80,8** %
 Power factor **0,75 0,69 0,56 0,35**

Sound pressure level (1m) **65,6** dB(A)
 Resistance R20 (open) **0,549** Ω
 Resistance R20 **Δ 0,366** Ω

Full load torque **196,23** Nm
 DOL Starting torque vs FL torque **2,19**
 DOL Pull up torque vs FL torque **1,56**
 DOL Pull out torque vs FL torque **2,92**
 Star-Delta Starting torque vs FL torque **0,68**
 Star-Delta Pull up torque vs FL torque **0,49**
 Star-Delta Pull out torque vs FL torque **0,91**
 DOL Starting current vs FL current **6,27**
 Star Delta Starting current vs FL current **1,96**
 Rotor Inertia **0,3250** kgm2

Bearing DE **6312 - ZZ C3**
 Bearing NDE **6312 - ZZ C3**

WI	Change	date	sign.
Dutchi Motors B.V.		Description	date
P.O. Box 5390		Drawing made by :	27-04-04
NL-6802 EJ ARNHEM			
Tel : +31-(0)26 - 3541 600		dutchi.motors@dutchi.nl	
Fax : +31-(0)26 - 3541 650		www.dutchi.com	

Power is our commodity, the world is our market !

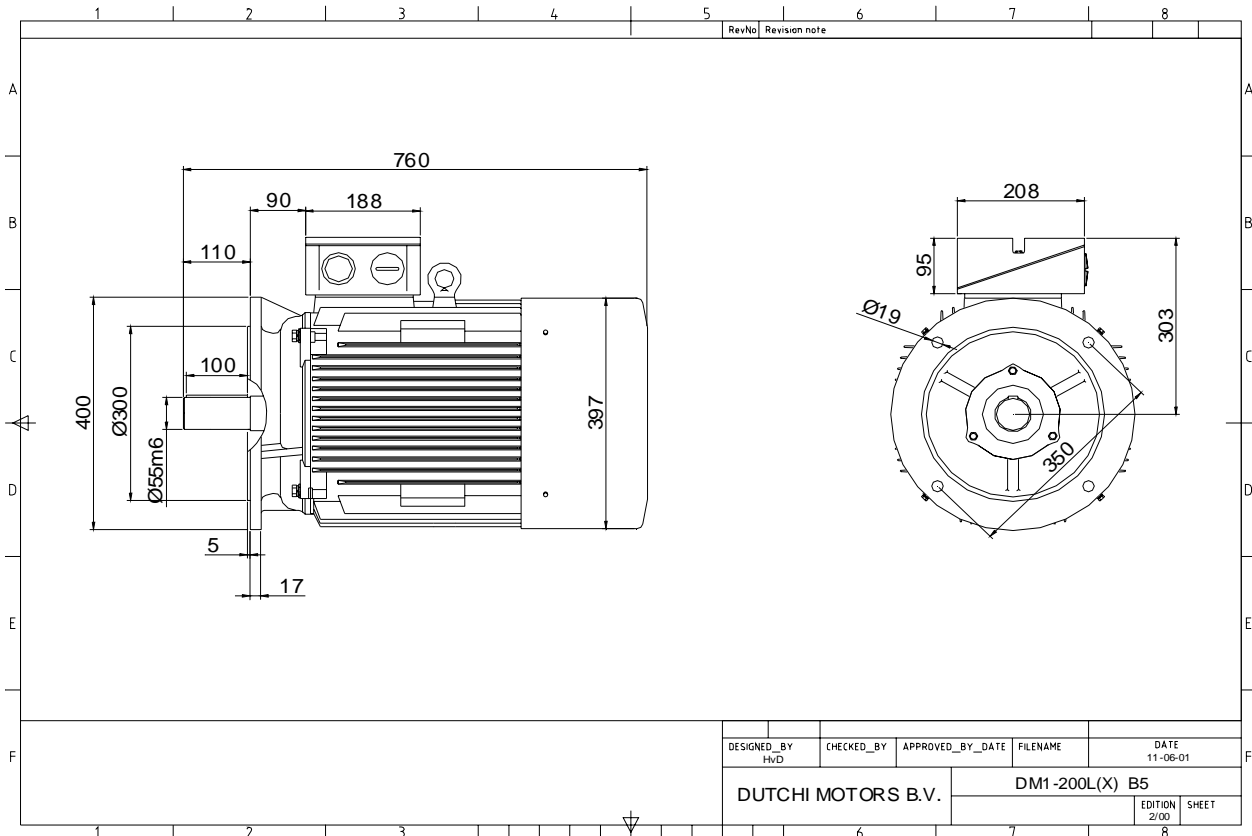

Specification **IEC 60034-1**
 Manufacturer **Dutchi Motors B.V.**
 Motor type **DM1- 200 L8**
 Rated power **15** kW **S1** duty
 Speed **730** r.p.m
 Voltage **400 / 690** V
 Frequency **50** Hz
 Connection **Δ / Y**
 Amps full load **32,4 / 18,7** A
 Amps no-load(400V) **17,80** A
 Enclosure **IP 55**
 Insulation Class **F (temp. rise B (80 K))**

Max. coolant temp. **40°C**
 Max. altitude **1.000** mtr, above sea level
 Comment **3 x PTC 150°C**
 Cable entries **2 x M50x1,5 + 1 x M20x1,5 (ptc)**

Feature **Cast-iron motor**
 Weight **230** kg
 Catalog no. **11238A15D**
 Warranty **12~18 months**

Efficiency class **N/A**
 Load data 100% 75% 50% 25%
 Efficiency **89,3 89,3 87,7 80,8** %
 Power factor **0,75 0,69 0,56 0,35**

Sound pressure level (1m) **65,6** dB(A)
 Resistance R20 (open) **0,549** Ω
 Resistance R20 **Δ 0,366** Ω

Full load torque **196,23** Nm
 DOL Starting torque vs FL torque **2,19**
 DOL Pull up torque vs FL torque **1,56**
 DOL Pull out torque vs FL torque **2,92**
 Star-Delta Starting torque vs FL torque **0,68**
 Star-Delta Pull up torque vs FL torque **0,49**
 Star-Delta Pull out torque vs FL torque **0,91**
 DOL Starting current vs FL current **6,27**
 Star Delta Starting current vs FL current **1,96**
 Rotor Inertia **0,3250** kgm2

Bearing DE **6312 - ZZ C3**
 Bearing NDE **6312 - ZZ C3**

WI	Change	date	sign.
Dutchi Motors B.V. P.O. Box 5390 NL-6802 EJ ARNHEM Tel : +31-(0)26 - 3541 600 Fax : +31-(0)26 - 3541 650		Discription Drawing made by : 27-04-04	date sign. HvD
dutchi.motors@dutchi.nl www.dutchi.com			