

Power is our commodity, the world is our market !

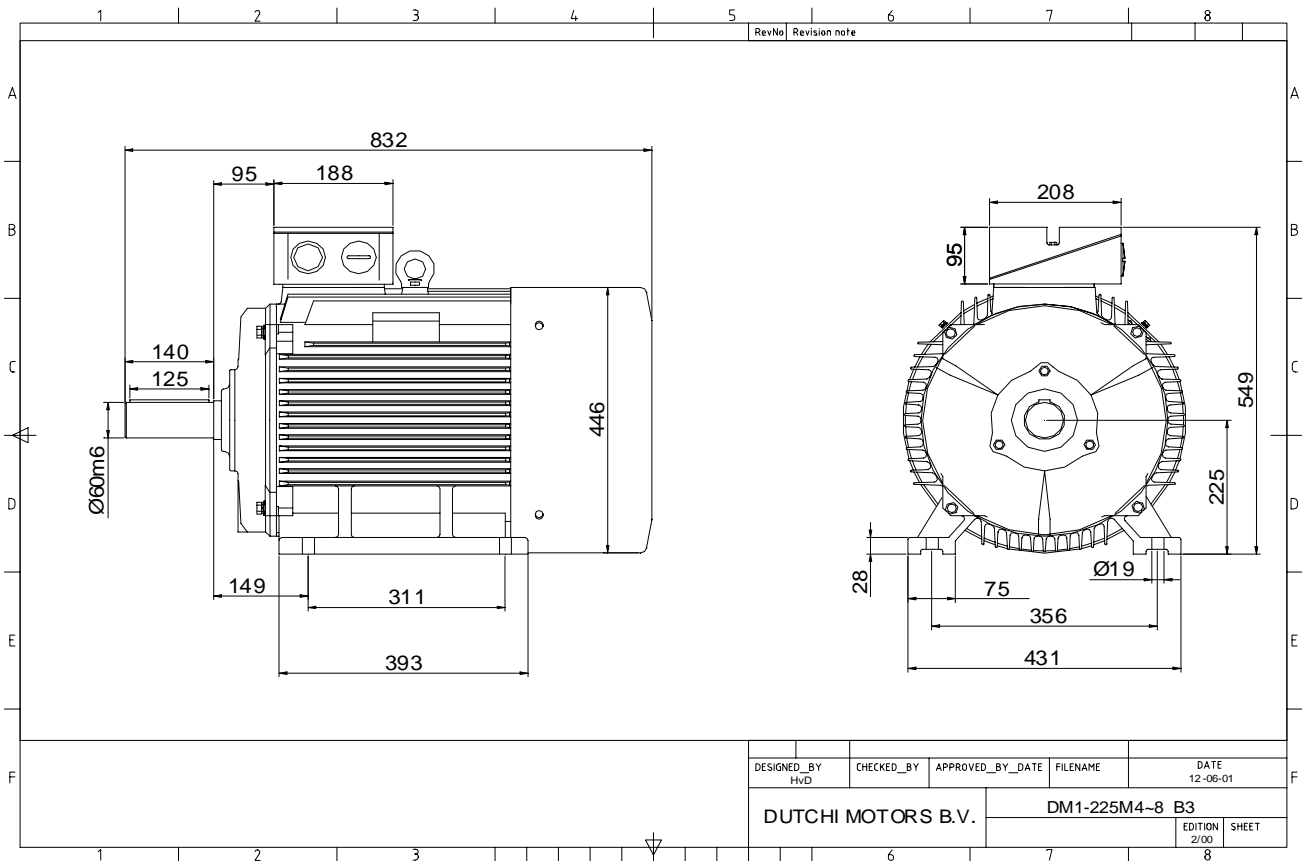

Specification **IEC 60034-1**  
 Manufacturer **Dutchi Motors B.V.**  
 Motor type **DM1- 225 M8**  
 Rated power **22** kW **S1** duty  
 Speed **730** r.p.m  
 Voltage **400 / 690** V  
 Frequency **50** Hz  
 Connection **Δ / Y**  
 Amps full load **43,6 / 25,2** A  
 Amps no-load(400V) **21,90** A  
 Enclosure **IP 55**  
 Insulation Class **F (temp. rise B (80 K))**

Max. coolant temp. **40°C**  
 Max. altitude **1.000** mtr, above sea level  
 Comment **3 x PTC 150°C**  
 Cable entries **2 x M50x1,5 + 1 x M20x1,5 (ptc)**

Feature **Cast-iron motor**  
 Weight **294** kg  
 Catalog no. **11138A22D**  
 Warranty **12~18 months**

Efficiency class **N/A**  
 Load data 100% 75% 50% 25%  
 Efficiency **91,2 91,5 90,4 85,1** %  
 Power factor **0,80 0,75 0,64 0,41**

Sound pressure level (1m) **61,3** dB(A)  
 Resistance R20 (open) **0,351** Ω  
 Resistance R20 **Δ 0,234** Ω

Full load torque **287,81** Nm  
 DOL Starting torque vs FL torque **2,15**  
 DOL Pull up torque vs FL torque **1,55**  
 DOL Pull out torque vs FL torque **2,97**  
 Star-Delta Starting torque vs FL torque **0,67**  
 Star-Delta Pull up torque vs FL torque **0,48**  
 Star-Delta Pull out torque vs FL torque **0,93**  
 DOL Starting current vs FL current **7,09**  
 Star Delta Starting current vs FL current **2,21**  
 Rotor Inertia **0,5310** kgm<sup>2</sup>

Bearing DE **6313 - ZZ C3**  
 Bearing NDE **6313 - ZZ C3**

WI	Change	date	sign.
<b>Dutchi Motors B.V.</b> P.O. Box 5390 NL-6802 EJ ARNHEM Tel : +31-(0)26 - 3541 600 Fax : +31-(0)26 - 3541 650	Description	date	sign.
	Drawing made by :	27-04-04	HvD
	<b>dutchi.motors@dutchi.nl</b> <b>www.dutchi.com</b>		

Power is our commodity, the world is our market !

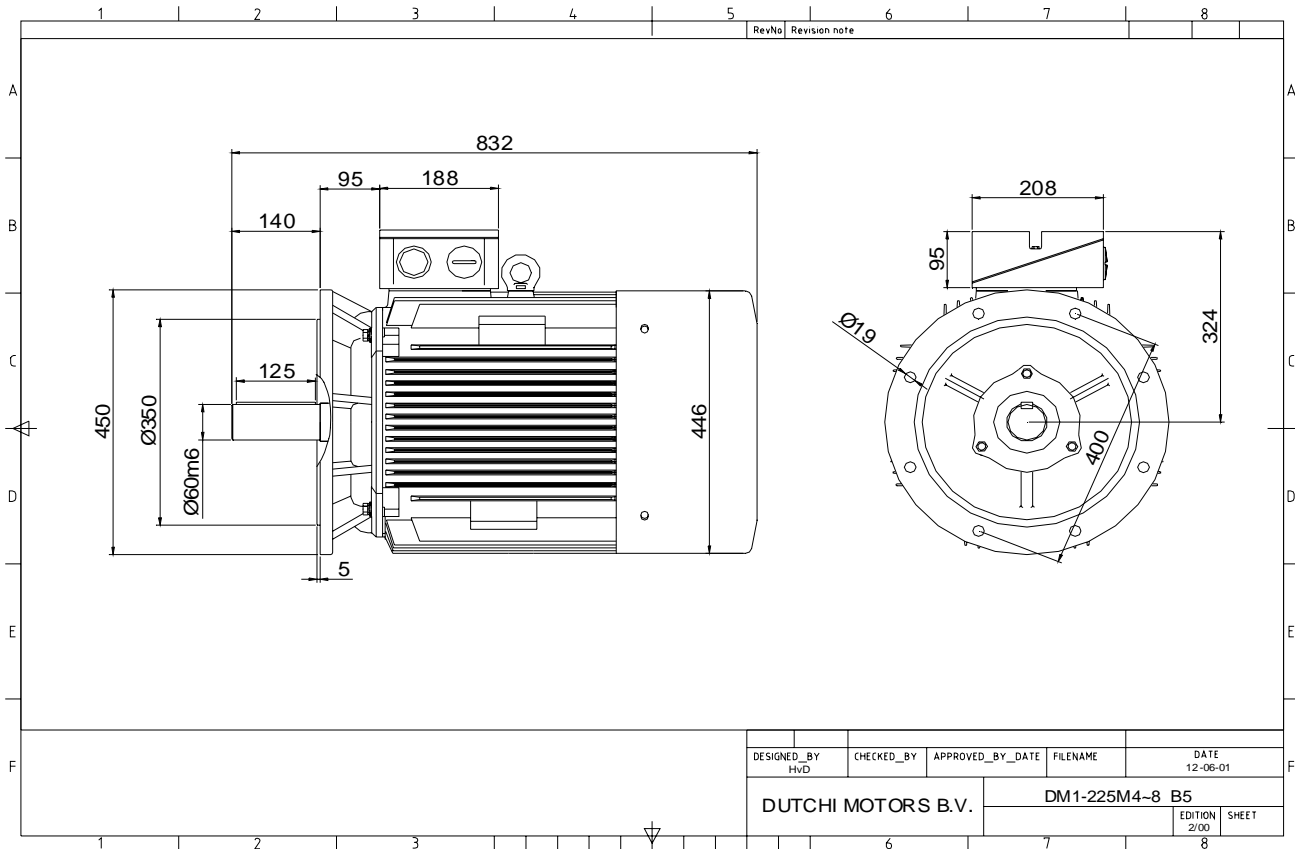

DESIGNED_BY HvD	CHECKED_BY	APPROVED_BY_DATE	FILENAME	DATE 12-06-01
DUTCHI MOTORS B.V.			DM1-225M4-8 B5	EDITION 2/00
				SHEET 8

Specification	<b>IEC 60034-1</b>
Manufacturer	<b>Dutchi Motors B.V.</b>
Motor type	<b>DM1- 225 M8</b>
Rated power	<b>22</b> kW <b>S1</b> duty
Speed	<b>730</b> r.p.m
Voltage	<b>400</b> / <b>690</b> V
Frequency	<b>50</b> Hz
Connection	<b>Δ</b> / <b>Y</b>
Amps full load	<b>43,6</b> / <b>25,2</b> A
Amps no-load(400V)	<b>21,90</b> A
Enclosure	<b>IP 55</b>
Insulation Class	<b>F (temp. rise B (80 K))</b>
Max. coolant temp.	<b>40°C</b>
Max. altitude	<b>1.000</b> mtr, above sea level
Comment	<b>3 x PTC 150°C</b>
Cable entries	<b>2 x M50x1,5 + 1 x M20x1,5 (ptc)</b>
Feature	<b>Cast-iron motor</b>
Weight	<b>294</b> kg
Catalog no.	<b>11538A22D</b>
Warranty	<b>12~18 months</b>

Efficiency class	<b>N/A</b>			
Load data	100%	75%	50%	25%
Efficiency	<b>91,2</b>	<b>91,5</b>	<b>90,4</b>	<b>85,1</b> %
Power factor	<b>0,80</b>	<b>0,75</b>	<b>0,64</b>	<b>0,41</b>
Sound pressure level (1m)				<b>61,3</b> dB(A)
Resistance R20 (open)				<b>0,351</b> Ω
Resistance R20	<b>Δ</b>			<b>0,234</b> Ω
Full load torque				<b>287,81</b> Nm
DOL Starting torque vs FL torque				<b>2,15</b>
DOL Pull up torque vs FL torque				<b>1,55</b>
DOL Pull out torque vs FL torque				<b>2,97</b>
Star-Delta Starting torque vs FL torque				<b>0,67</b>
Star-Delta Pull up torque vs FL torque				<b>0,48</b>
Star-Delta Pull out torque vs FL torque				<b>0,93</b>
DOL Starting current vs FL current				<b>7,09</b>
Star Delta Starting current vs FL current				<b>2,21</b>
Rotor Inertia				<b>0,5310</b> kgm <sup>2</sup>
Bearing DE				<b>6313 - ZZ C3</b>
Bearing NDE				<b>6313 - ZZ C3</b>

WI	Change	date	sign.
Dutchi Motors B.V.		Description	date
P.O. Box 5390		Drawing made by :	27-04-04
NL-6802 EJ ARNHEM			
Tel : +31-(0)26 - 3541 600		<b>dutchi.motors@dutchi.nl</b>	
Fax : +31-(0)26 - 3541 650		<b>www.dutchi.com</b>	