

Power is our commodity, the world is our market !

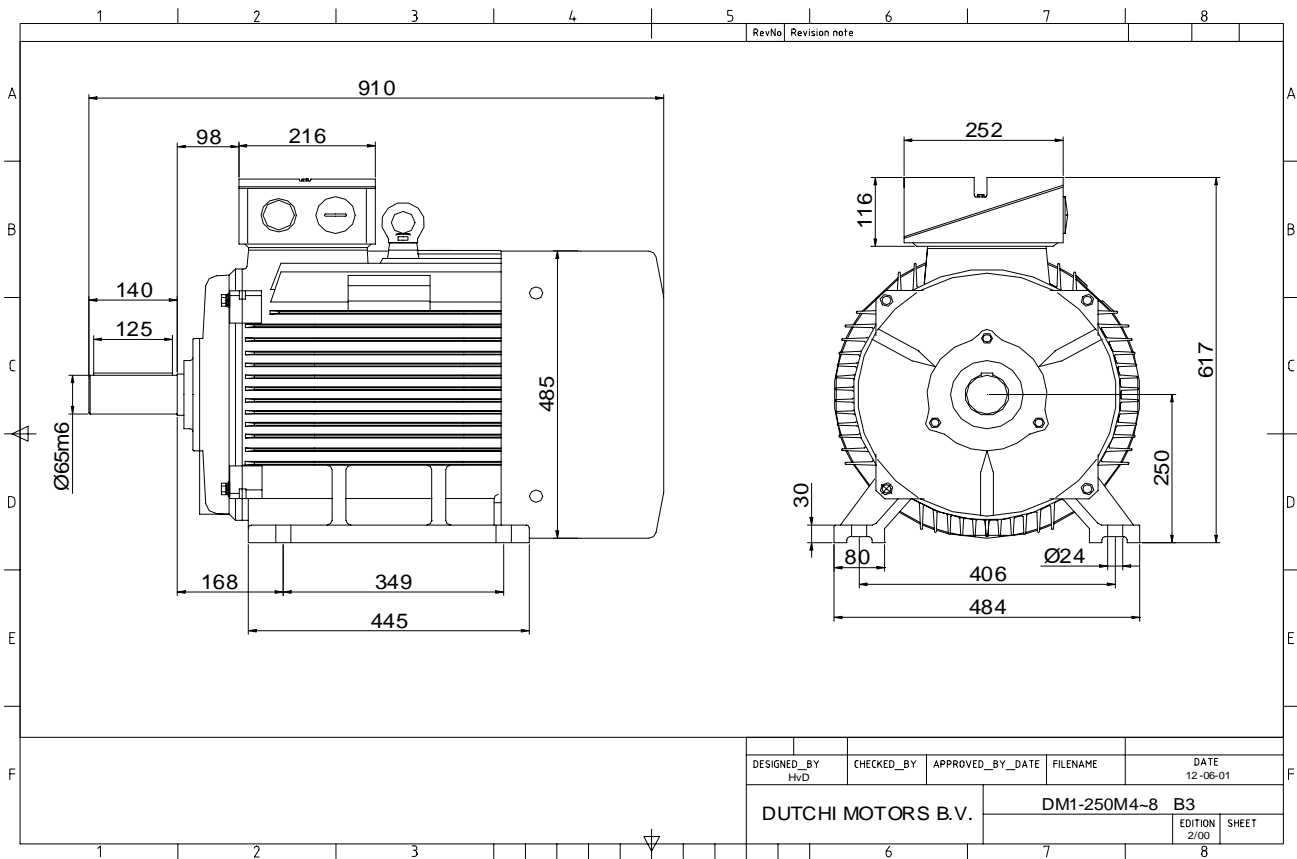

Specification **IEC 60034-1**
 Manufacturer **Dutchi Motors B.V.**
 Motor type **DM1- 250 M4**
 Rated power **55,00 kW S1** duty
 Speed **1475** r.p.m
 Voltage **400 / 690** V
 Frequency **50** Hz
 Connection **Δ / Y**
 Amps full load **97,8 / 56,5** A
 Amps no-load(400V) **32,55** A
 Enclosure **IP 55**
 Insulation Class **F (temp. rise B (80 K))**

Max. coolant temp. **40°C**
 Max. altitude **1.000** mtr, above sea level
 Comment **3 x PTC 150°C**
 Cable entries **2 x M63x1,5 + 1 x M20x1,5 (ptc)**

Feature **Cast-iron motor**
 Weight **381** kg
 Catalog no. **11134A55D**
 Warranty **12~18 months**

Efficiency class **EFF 2**
 Load data 100% 75% 50% 25%
 Efficiency **93,7 93,9 93,2 89,3** %
 Power factor **0,87 0,84 0,76 0,56**

Sound pressure level (1m) **70,6** dB(A)
 Resistance R20 (open) **0,103** Ω
 Resistance R20 **Δ 0,069** Ω

Full load torque **356,10** Nm
 DOL Starting torque vs FL torque **2,34**
 DOL Pull up torque vs FL torque **1,68**
 DOL Pull out torque vs FL torque **3,20**
 Star-Delta Starting torque vs FL torque **0,73**
 Star-Delta Pull up torque vs FL torque **0,53**
 Star-Delta Pull out torque vs FL torque **1,00**
 DOL Starting current vs FL current **7,16**
 Star Delta Starting current vs FL current **2,24**
 Rotor Inertia **0,6400** kgm²

Bearing DE **6314 - ZZ C3**
 Bearing NDE **6314 - ZZ C3**

WI	Change	date	sign.
Dutchi Motors B.V.		Description	date
P.O. Box 5390		Drawing made by :	27-04-04
NL-6802 EJ ARNHEM			
Tel : +31-(0)26 - 3541 600		dutchi.motors@dutchi.nl	
Fax : +31-(0)26 - 3541 650		www.dutchi.com	

Power is our commodity, the world is our market !

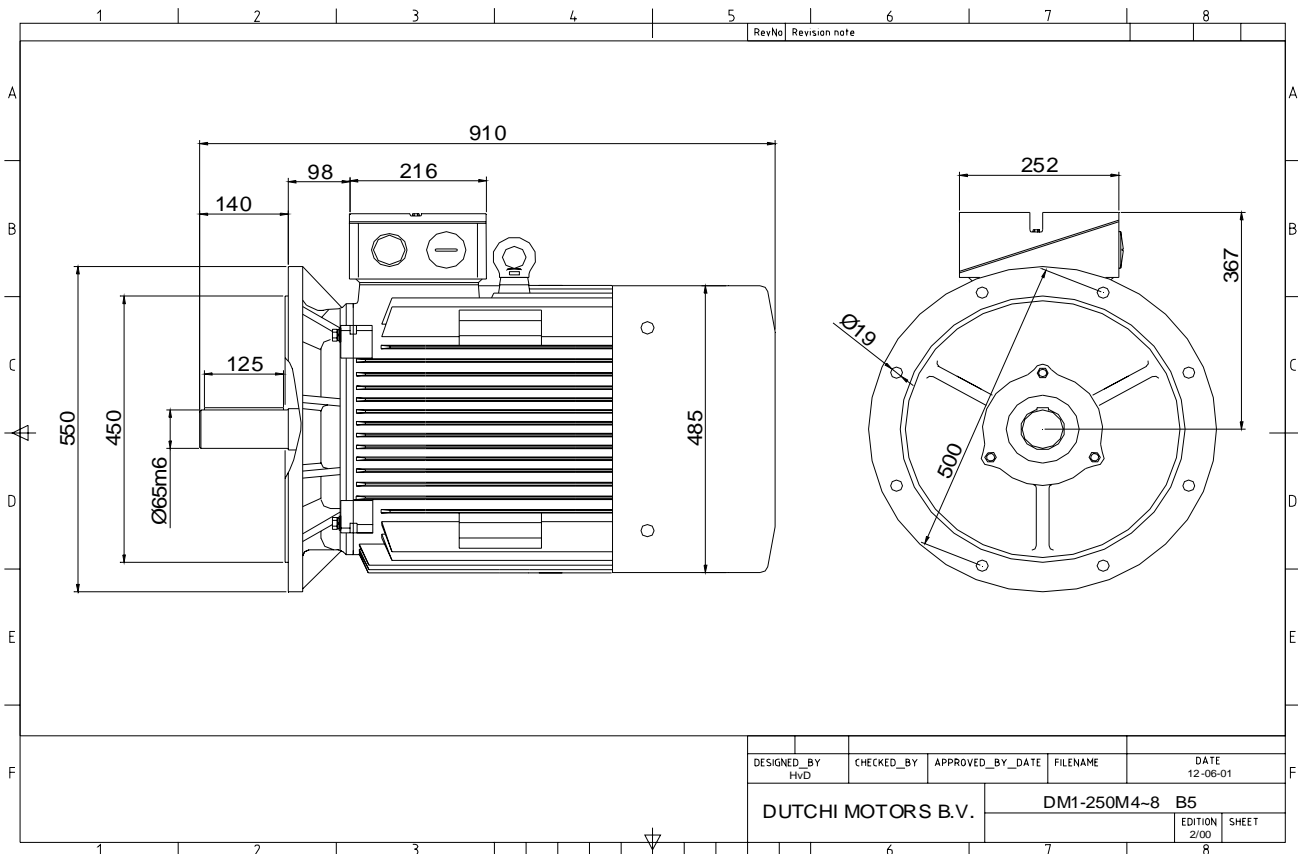

Specification **IEC 60034-1**
 Manufacturer **Dutchi Motors B.V.**
 Motor type **DM1- 250 M4**
 Rated power **55,00 kW S1** duty
 Speed **1475** r.p.m
 Voltage **400 / 690** V
 Frequency **50** Hz
 Connection **Δ / Y**
 Amps full load **97,8 / 56,5** A
 Amps no-load(400V) **32,55** A
 Enclosure **IP 55**
 Insulation Class **F (temp. rise B (80 K))**

Max. coolant temp. **40°C**
 Max. altitude **1.000** mtr, above sea level
 Comment **3 x PTC 150°C**
 Cable entries **2 x M63x1,5 + 1 x M20x1,5 (ptc)**

Feature **Cast-iron motor**
 Weight **381** kg
 Catalog no. **11234A55D**
 Warranty **12~18 months**

Efficiency class **EFF 2**
 Load data 100% 75% 50% 25%
 Efficiency **93,7 93,9 93,2 89,3** %
 Power factor **0,87 0,84 0,76 0,56**

Sound pressure level (1m) **70,6** dB(A)
 Resistance R20 (open) **0,103** Ω
 Resistance R20 **Δ 0,069** Ω

Full load torque **356,10** Nm
 DOL Starting torque vs FL torque **2,34**
 DOL Pull up torque vs FL torque **1,68**
 DOL Pull out torque vs FL torque **3,20**
 Star-Delta Starting torque vs FL torque **0,73**
 Star-Delta Pull up torque vs FL torque **0,53**
 Star-Delta Pull out torque vs FL torque **1,00**
 DOL Starting current vs FL current **7,16**
 Star Delta Starting current vs FL current **2,24**
 Rotor Inertia **0,6400** kgm2

Bearing DE **6314 - ZZ C3**
 Bearing NDE **6314 - ZZ C3**

WI	Change	date	sign.
Dutchi Motors B.V.		Description	date
P.O. Box 5390		Drawing made by :	27-04-04
NL-6802 EJ ARNHEM			
Tel : +31-(0)26 - 3541 600		dutchi.motors@dutchi.nl	
Fax : +31-(0)26 - 3541 650		www.dutchi.com	