

Power is our commodity, the world is our market !

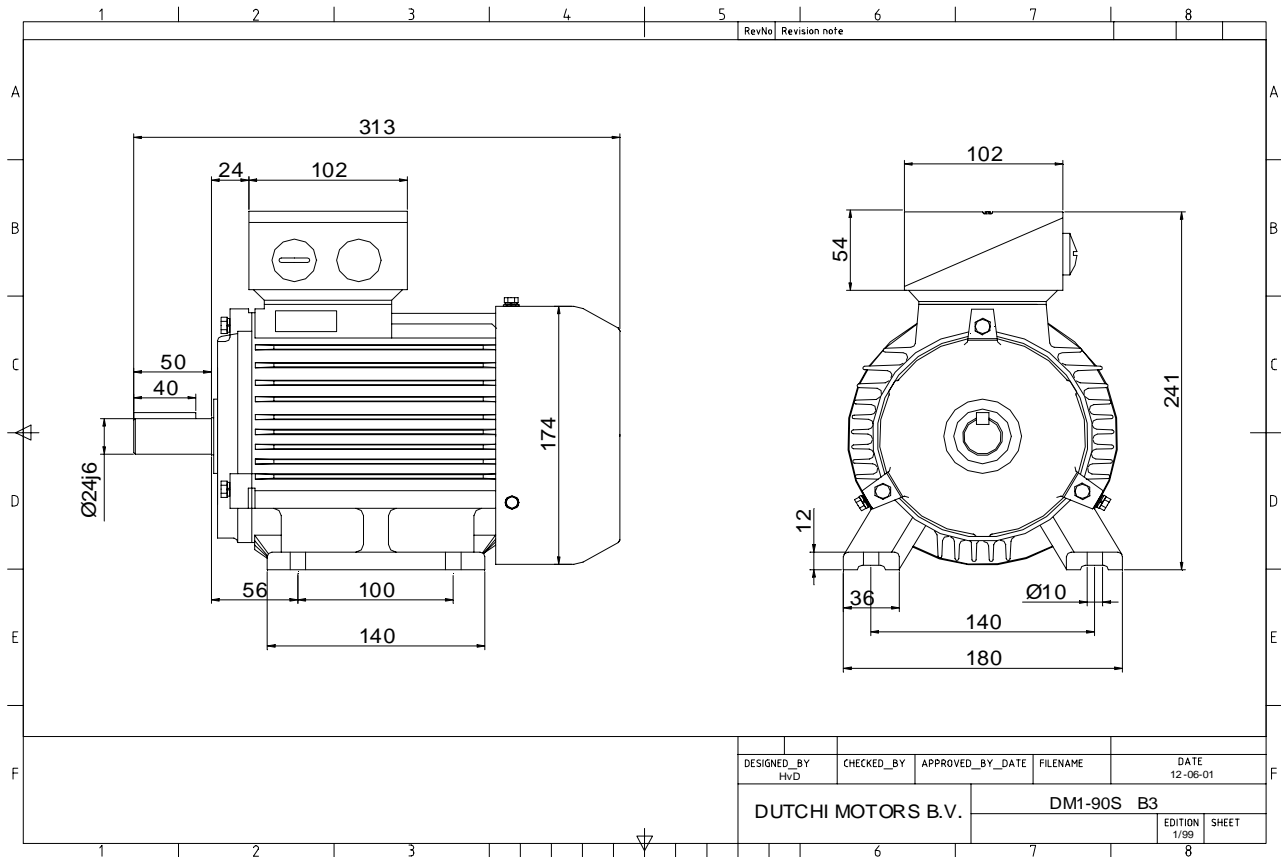

Specification **IEC 60034-1**  
 Manufacturer **Dutchi Motors B.V.**  
 Motor type **DM1-HE 90S2**  
 Rated power **1,50** kW **S1** duty  
 Speed **2840** r.p.m  
 Voltage **230** / **400** V  
 Frequency **50** Hz  
 Connection **Δ** / **Y**  
 Amps full load **5,3** / **3,1** A  
 Amps no-load(400V) **1,38** A  
 Enclosure **IP 55**  
 Insulation Class **F (temp. rise B (80 K))**

Max. coolant temp. **40°C**  
 Max. altitude **1.000** mtr, above sea level  
 Comment **3 x PTC 150°C**  
 Cable entries **2 x M25x1,5 + 1 x M20x1,5 (ptc)**

Feature **Cast-iron motor**  
 Weight **kg**  
 Catalog no. **11122150DH**  
 Warranty **12~18 months**

Efficiency class **EFF 1**  
 Load data 100% 75% 50% 25%  
 Efficiency **85,3 86,0 84,9 78,1** %  
 Power factor **0,83 0,78 0,67 0,46**

Sound pressure level (1m) **51,4** dB(A)  
 Resistance R20 (open) **3,263** Ω  
 Resistance R20 **Y 6,527** Ω

Full load torque **5** Nm  
 DOL Starting torque vs FL torque **3,09**  
 DOL Pull up torque vs FL torque **1,91**  
 DOL Pull out torque vs FL torque **3,46**  
 Star-Delta Starting torque vs FL torque **Y - motor**  
 Star-Delta Pull up torque vs FL torque **Y - motor**  
 Star-Delta Pull out torque vs FL torque **Y - motor**  
 DOL Starting current vs FL current **7,91**  
 Star Delta Starting current vs FL current **Y - motor**

Rotor Inertia **kgm2**

Bearing DE **6205 - ZZ**  
 Bearing NDE **6205 - ZZ**

WI	Change	date	sign.
<b>Dutchi Motors B.V.</b> P.O. Box 5390 NL-6802 EJ ARNHEM Tel : +31-(0)26 - 3541 600 Fax : +31-(0)26 - 3541 650		Discription	date
		Drawing made by :	27-04-04
		<b>dutchi.motors@dutchi.nl</b> <b>www.dutchi.com</b>	

Power is our commodity, the world is our market !

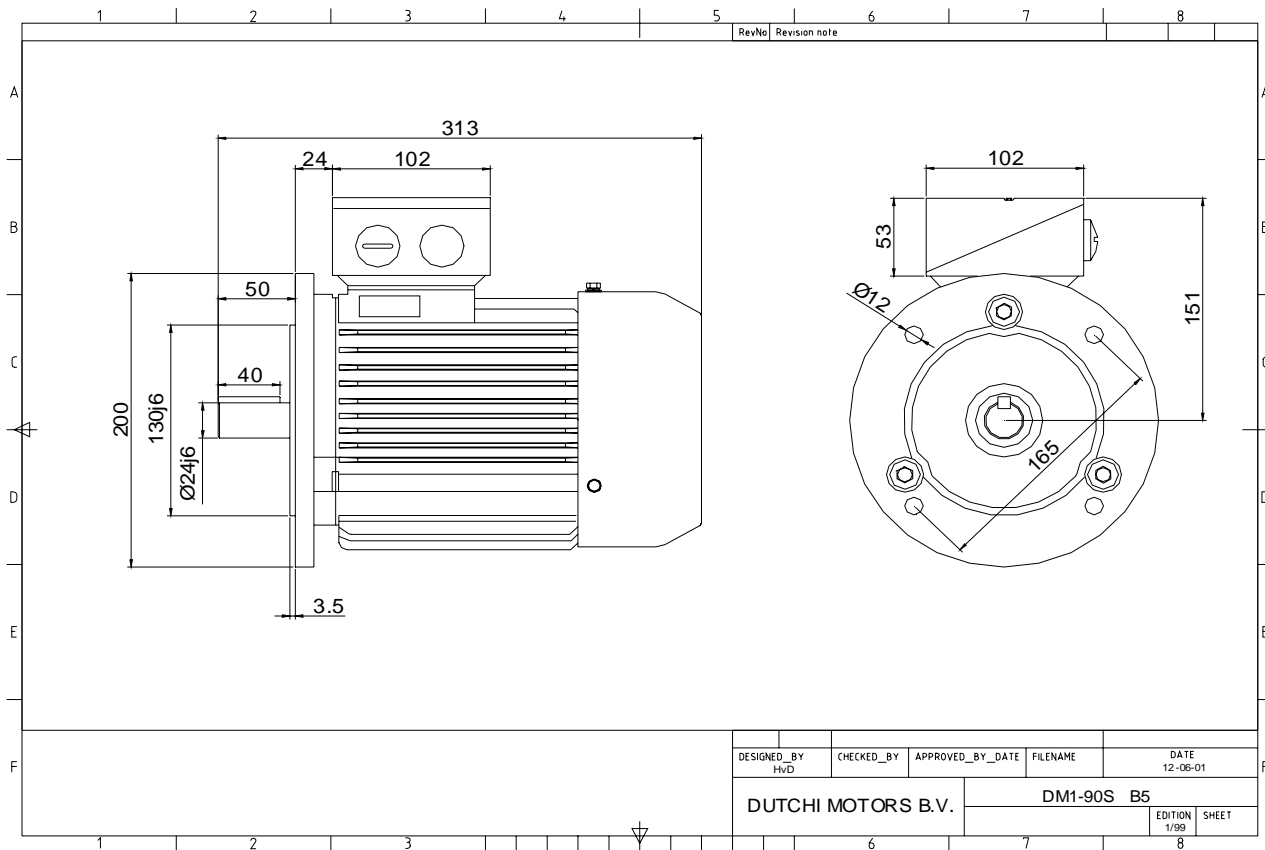

DESIGNED_BY HvD	CHECKED_BY	APPROVED_BY_DATE	FILENAME	DATE 12-06-01
DUTCHI MOTORS B.V.		DM1-90S B5		EDITION 1/00
				SHEET

Specification	<b>IEC 60034-1</b>
Manufacturer	<b>Dutchi Motors B.V.</b>
Motor type	<b>DM1-HE 90S2</b>
Rated power	<b>1,50</b> kW <b>S1</b> duty
Speed	<b>2840</b> r.p.m
Voltage	<b>230 / 400</b> V
Frequency	<b>50</b> Hz
Connection	<b>Δ / Y</b>
Amps full load	<b>5,3 / 3,1</b> A
Amps no-load(400V)	<b>1,38</b> A
Enclosure	<b>IP 55</b>
Insulation Class	<b>F (temp. rise B (80 K))</b>
Max. coolant temp.	<b>40°C</b>
Max. altitude	<b>1.000</b> mtr, above sea level
Comment	<b>3 x PTC 150°C</b>
Cable entries	<b>2 x M25x1,5 + 1 x M20x1,5 (ptc)</b>
Feature	<b>Cast-iron motor</b>
Weight	kg
Catalog no.	<b>11222150DH</b>
Warranty	<b>12~18 months</b>

Efficiency class	<b>EFF 1</b>			
Load data	100%	75%	50%	25%
Efficiency	<b>85,3</b>	<b>86,0</b>	<b>84,9</b>	<b>78,1</b> %
Power factor	<b>0,83</b>	<b>0,78</b>	<b>0,67</b>	<b>0,46</b>
Sound pressure level (1m)				<b>51,4</b> dB(A)
Resistance R20 (open)				<b>3,263</b> Ω
Resistance R20	<b>Y</b>		<b>6,527</b> Ω	
Full load torque				<b>5</b> Nm
DOL Starting torque vs FL torque				<b>3,09</b>
DOL Pull up torque vs FL torque				<b>1,91</b>
DOL Pull out torque vs FL torque				<b>3,46</b>
Star-Delta Starting torque vs FL torque				<b>Y - motor</b>
Star-Delta Pull up torque vs FL torque				<b>Y - motor</b>
Star-Delta Pull out torque vs FL torque				<b>Y - motor</b>
DOL Starting current vs FL current				<b>7,91</b>
Star Delta Starting current vs FL current				<b>Y - motor</b>
Rotor Inertia				kgm <sup>2</sup>
Bearing DE				<b>6205 - ZZ</b>
Bearing NDE				<b>6205 - ZZ</b>

WI	Change	date	sign.
Dutchi Motors B.V.		Description	date
P.O. Box 5390		Drawing made by :	27-04-04
NL-6802 EJ ARNHEM			
Tel : +31-(0)26 - 3541 600		<b>dutchi.motors@dutchi.nl</b>	
Fax : +31-(0)26 - 3541 650		<b>www.dutchi.com</b>	