

Power is our commodity, the world is our market !

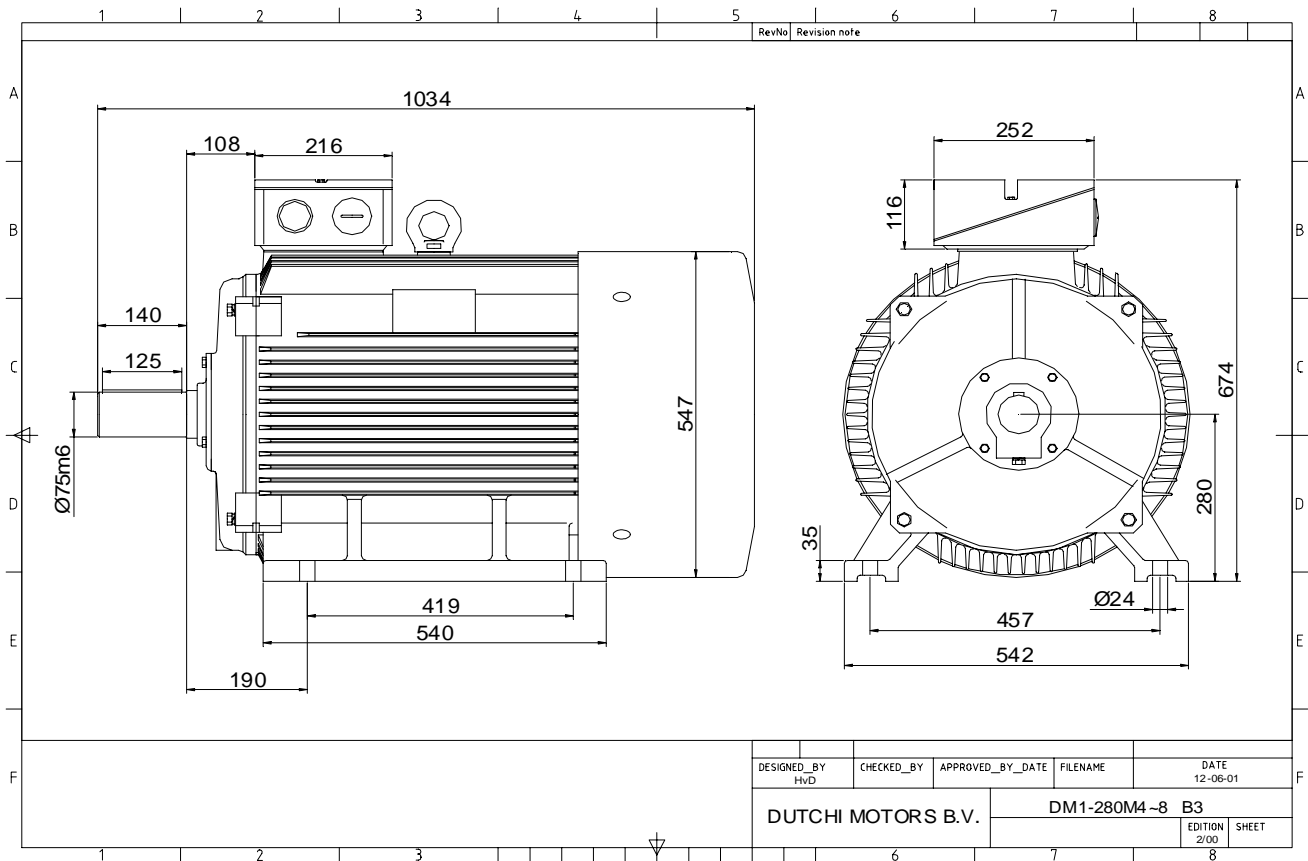

Specification **IEC 60034-1**
 Manufacturer **Dutchi Motors B.V.**
 Motor type **DM1-HE 280M4**
 Rated power **90,0** kW **S1** duty
 Speed **1485** r.p.m
 Voltage **400** / **690** V
 Frequency **50** Hz
 Connection **Δ** / **Y**
 Amps full load **152,2** / **87,9** A
 Amps no-load(400V) **41,60** A
 Enclosure **IP 55**
 Insulation Class **F (temp. rise B (80 K))**

Max. coolant temp. **40°C**
 Max. altitude **1.000** mtr, above sea level
 Comment **3 x PTC 150°C**
 Cable entries **2 x M63x1,5 + 1 x M20x1,5 (ptc)**

Feature **Cast-iron motor**
 Weight kg
 Catalog no. **11134A90DH**
 Warranty **12~18 months**

Efficiency class **EFF 1**
 Load data 100% 75% 50% 25%
 Efficiency **95,3 95,4 94,9 91,9** %
 Power factor **0,90 0,89 0,83 0,62**

Sound pressure level (1m) **67,4** dB(A)
 Resistance R20 (open) **0,052** Ω
 Resistance R20 **Δ 0,035** Ω

Full load torque **579** Nm
 DOL Starting torque vs FL torque **2,08**
 DOL Pull up torque vs FL torque **1,58**
 DOL Pull out torque vs FL torque **3,38**
 Star-Delta Starting torque vs FL torque **0,65**
 Star-Delta Pull up torque vs FL torque **0,49**
 Star-Delta Pull out torque vs FL torque **1,05**
 DOL Starting current vs FL current **7,10**
 Star Delta Starting current vs FL current **2,22**

Rotor Inertia kgm²
 Bearing DE **6317 - C3**
 Bearing NDE **6317 - C3**

WI	Change	date	sign.
Dutchi Motors B.V.		Description	date
P.O. Box 5390		Drawing made by :	27-04-04
NL-6802 EJ ARNHEM			
Tel : +31-(0)26 - 3541 600		dutchi.motors@dutchi.nl	
Fax : +31-(0)26 - 3541 650		www.dutchi.com	

Power is our commodity, the world is our market !

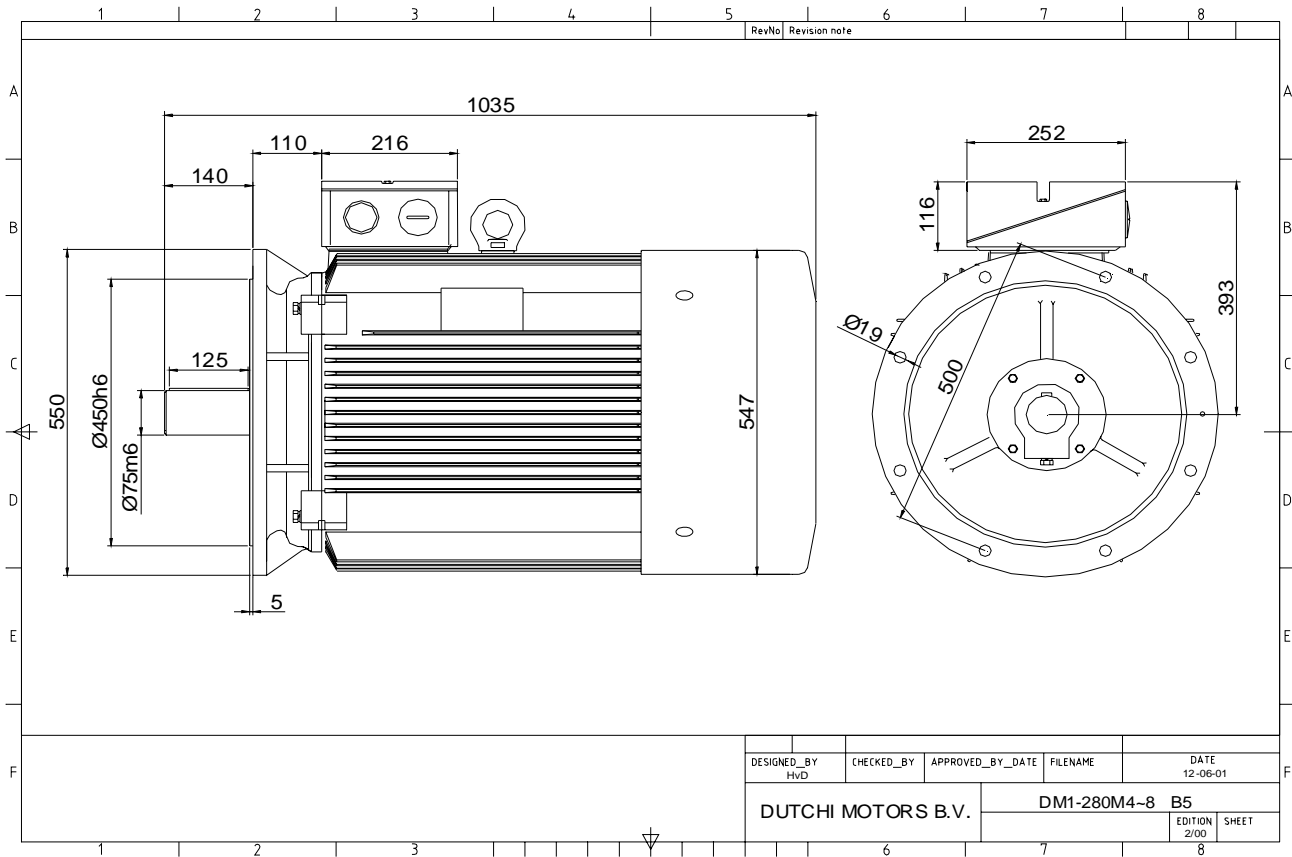

Specification	IEC 60034-1
Manufacturer	Dutchi Motors B.V.
Motor type	DM1-HE 280M4
Rated power	90,0 kW S1 duty
Speed	1485 r.p.m
Voltage	400 / 690 V
Frequency	50 Hz
Connection	Δ / Y
Amps full load	152,2 / 87,9 A
Amps no-load(400V)	41,60 A
Enclosure	IP 55
Insulation Class	F (temp. rise B (80 K))
Max. coolant temp.	40°C
Max. altitude	1.000 mtr, above sea level
Comment	3 x PTC 150°C
Cable entries	2 x M63x1,5 + 1 x M20x1,5 (ptc)
Feature	Cast-iron motor
Weight	kg
Catalog no.	11234A90DH
Warranty	12~18 months

Efficiency class	EFF 1			
Load data	100%	75%	50%	25%
Efficiency	95,3	95,4	94,9	91,9 %
Power factor	0,90	0,89	0,83	0,62
Sound pressure level (1m)				67,4 dB(A)
Resistance R20 (open)				0,052 Ω
Resistance R20	Δ			0,035 Ω
Full load torque				579 Nm
DOL Starting torque vs FL torque				2,08
DOL Pull up torque vs FL torque				1,58
DOL Pull out torque vs FL torque				3,38
Star-Delta Starting torque vs FL torque				0,65
Star-Delta Pull up torque vs FL torque				0,49
Star-Delta Pull out torque vs FL torque				1,05
DOL Starting current vs FL current				7,10
Star Delta Starting current vs FL current				2,22
Rotor Inertia				kgm ²
Bearing DE				6317 - C3
Bearing NDE				6317 - C3

WI	Change	date	sign.
Dutchi Motors B.V. P.O. Box 5390 NL-6802 EJ ARNHEM Tel : +31-(0)26 - 3541 600 Fax : +31-(0)26 - 3541 650		Discription Drawing made by : 27-04-04	date sign. HvD
dutchi.motors@dutchi.nl www.dutchi.com			