

Power is our commodity, the world is our market !

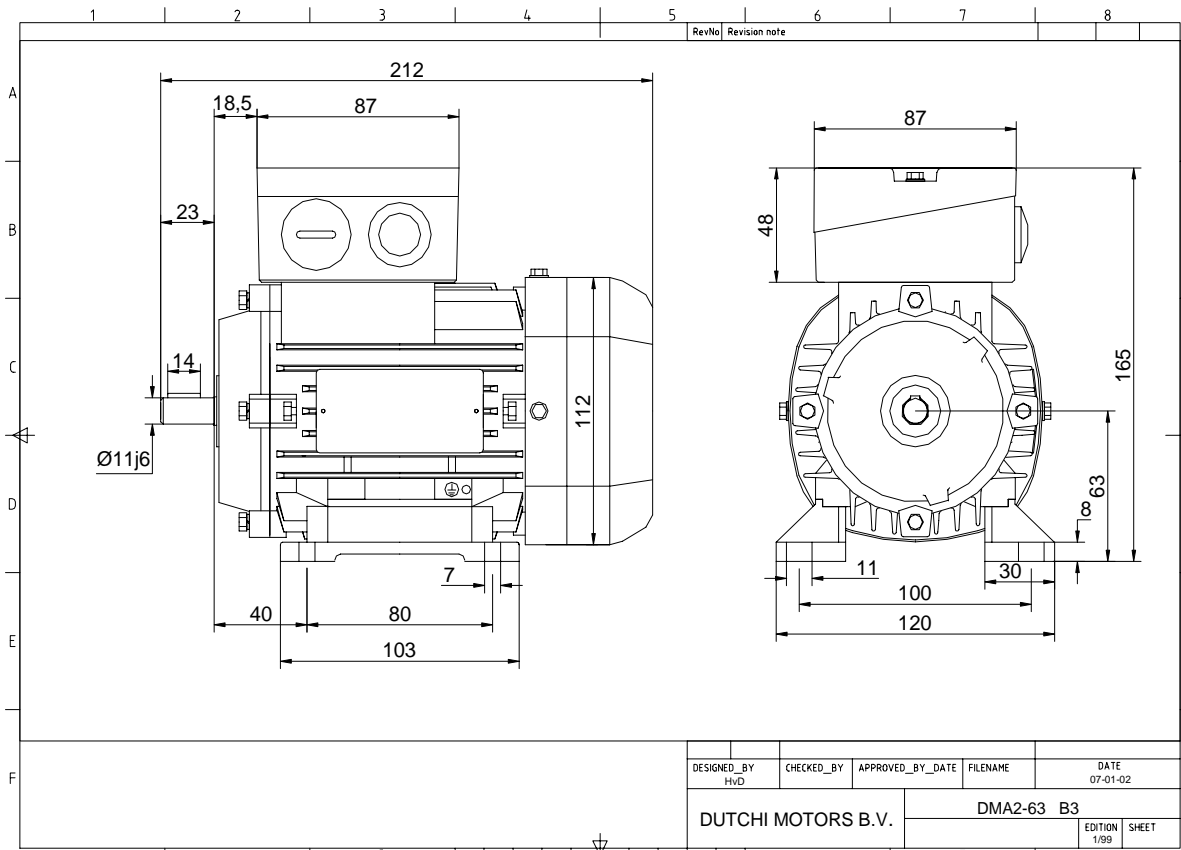

Specification **IEC 60034-1**  
 Manufacturer **Dutchi Motors B.V.**  
 Motor type **DMA2- 63 G4**  
 Rated power **0,18** kW **S1** duty  
 Speed **1315** r.p.m  
 Voltage **230 / 400** V  
 Frequency **50** Hz  
 Connection **Δ / Y**  
 Amps full load **1,21 / 0,70** A  
 Amps no-load(400V) **0,63** A  
 Enclosure **IP 55**  
 Insulation Class **F (temp. rise B (80 K))**

Max. coolant temp. **40°C**  
 Max. altitude **1.000** mtr, above sea level  
 Comment  
 Cable entries **2 x M20\*1,5**

Feature **Aluminium motor**  
 Weight **4,0** kg  
 Catalog no. **18124009D**  
 Warranty **12~18 months**

Efficiency class **N/A**  
 Load data 100% 75% 50% 25%  
 Efficiency **52,5 48,4 39,2 24,9** %  
 Power factor **0,71 0,60 0,48 0,38**

Sound pressure level (1m) **45,6** dB(A)  
 Resistance R20 (open) **46,01** Ω  
 Resistance R20 **Y 92,03** Ω

Full load torque **1,31** Nm  
 DOL Starting torque vs FL torque **2,22**  
 DOL Pull up torque vs FL torque **1,53**  
 DOL Pull out torque vs FL torque **2,76**  
 Star-Delta Starting torque vs FL torque **Y - motor**  
 Star-Delta Pull up torque vs FL torque **Y - motor**  
 Star-Delta Pull out torque vs FL torque **Y - motor**  
 DOL Starting current vs FL current **2,87**  
 Star Delta Starting current vs FL current **Y - motor**  
 Rotor Inertia **0,000136** kgm<sup>2</sup>

Bearing DE **6201 - ZZ**  
 Bearing NDE **6201 - ZZ**

WI	Change	date	sign.
<b>Dutchi Motors B.V.</b> P.O. Box 5390 NL-6802 EJ ARNHEM Tel : +31-(0)26 - 3541 600 Fax : +31-(0)26 - 3541 650		Discription	date
		Drawing made by :	19-04-04
		<b>dutchi.motors@dutchi.nl</b> <b>www.dutchi.com</b>	

Power is our commodity, the world is our market !

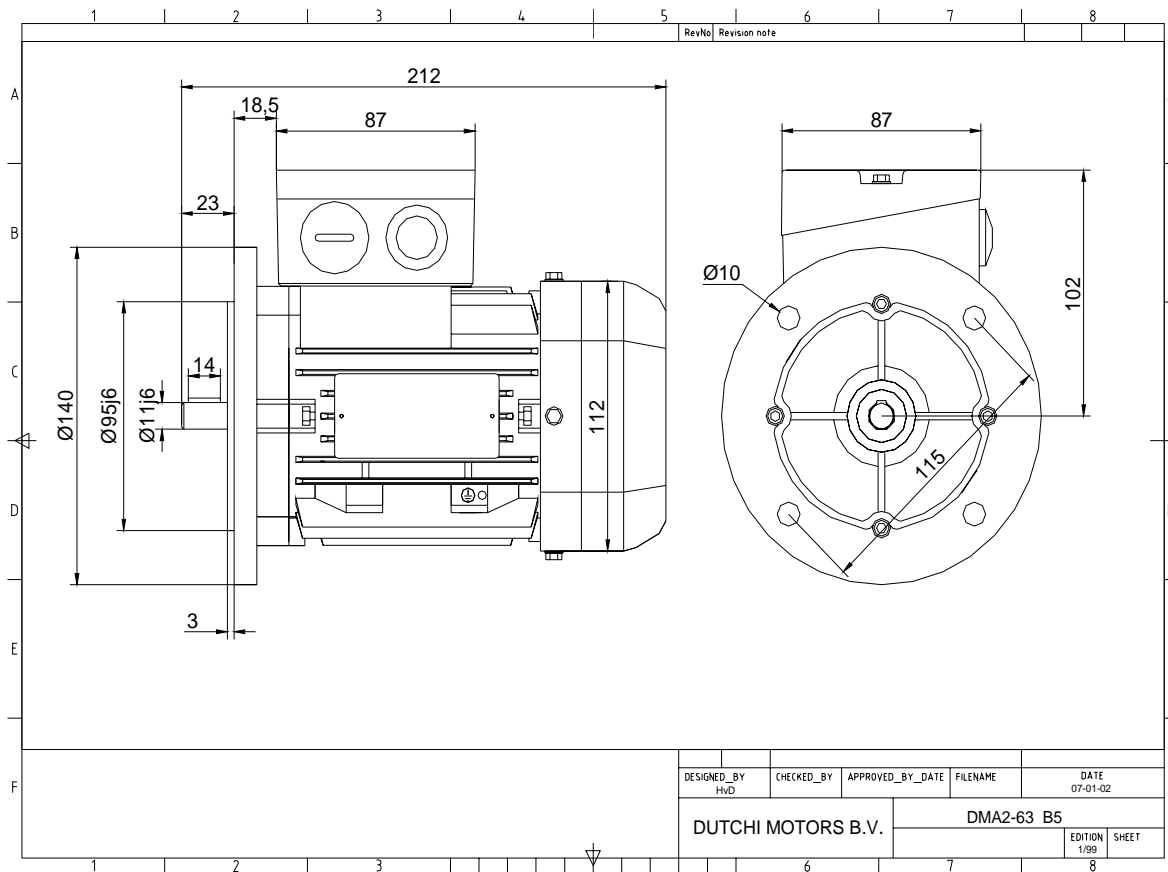

Specification **IEC 60034-1**  
 Manufacturer **Dutchi Motors B.V.**  
 Motor type **DMA2- 63 G4**  
 Rated power **0,18** kW **S1** duty  
 Speed **1315** r.p.m  
 Voltage **230 / 400** V  
 Frequency **50** Hz  
 Connection **Δ / Y**  
 Amps full load **1,21 / 0,70** A  
 Amps no-load(400V) **0,63** A  
 Enclosure **IP 55**  
 Insulation Class **F (temp. rise B (80 K))**

Max. coolant temp. **40°C**  
 Max. altitude **1.000** mtr, above sea level  
 Comment  
 Cable entries **2 x M20\*1,5**

Feature **Alumimium motor**  
 Weight **4,0** kg  
 Catalog no. **18224009D**  
 Warranty **12~18 months**

Efficiency class **N/A**  
 Load data 100% 75% 50% 25%  
 Efficiency **52,5 48,4 39,2 24,9** %  
 Power factor **0,71 0,60 0,48 0,38**

Sound pressure level (1m) **45,6** dB(A)  
 Resistance R20 (open) **46,01** Ω  
 Resistance R20 **Y 92,03** Ω

Full load torque **1,31** Nm  
 DOL Starting torque vs FL torque **2,22**  
 DOL Pull up torque vs FL torque **1,53**  
 DOL Pull out torque vs FL torque **2,76**  
 Star-Delta Starting torque vs FL torque **Y - motor**  
 Star-Delta Pull up torque vs FL torque **Y - motor**  
 Star-Delta Pull out torque vs FL torque **Y - motor**  
 DOL Starting current vs FL current **2,87**  
 Star Delta Starting current vs FL current **Y - motor**  
 Rotor Inertia **0,000136** kgm2

Bearing DE **6201 - ZZ**  
 Bearing NDE **6201 - ZZ**

WI	Change	date	sign.
Dutchi Motors B.V.		Description	date
P.O. Box 5390		Drawing made by :	19-04-04
NL-6802 EJ ARNHEM			
Tel : +31-(0)26 - 3541 600		<b>dutchi.motors@dutchi.nl</b>	
Fax : +31-(0)26 - 3541 650		<b>www.dutchi.com</b>	