

Power is our commodity, the world is our market !

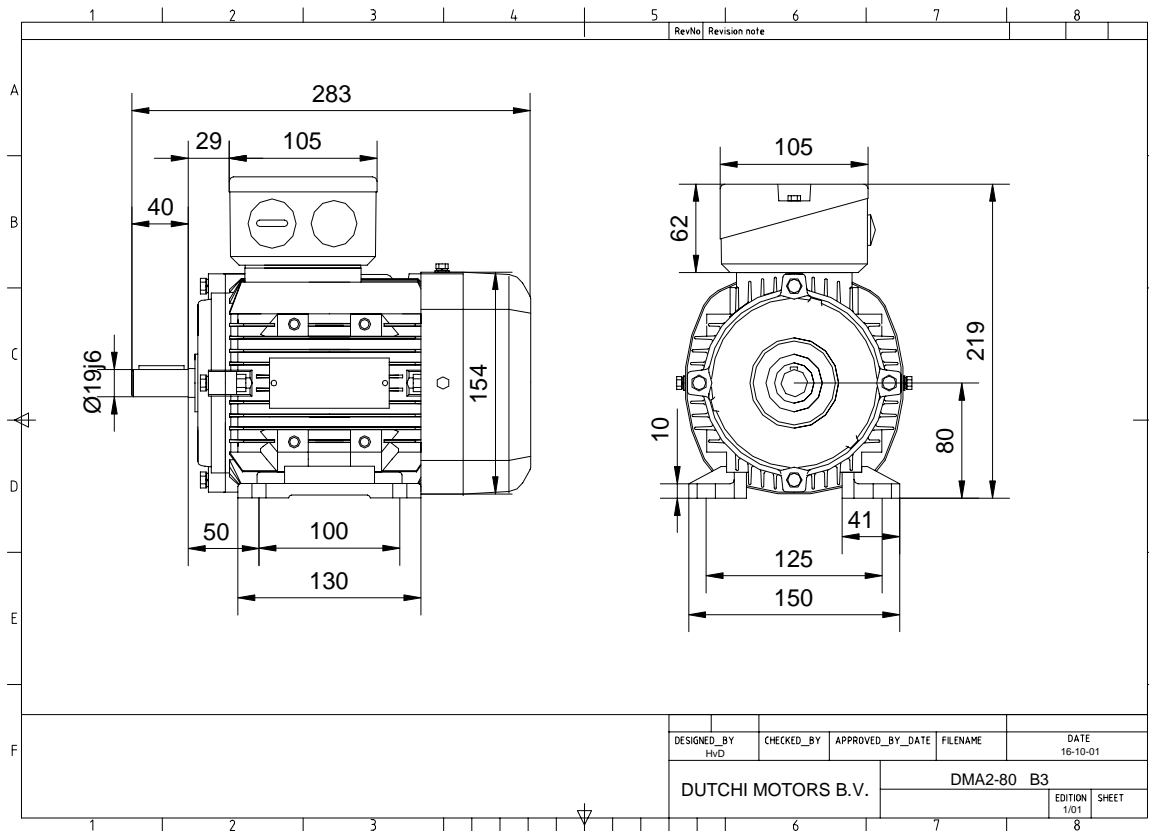

Specification **IEC 60034-1**
 Manufacturer **Dutchi Motors B.V.**
 Motor type **DMA2- 80 K2**
 Rated power **0,75** kW **S1** duty
 Speed **2875** r.p.m
 Voltage **230 / 400** V
 Frequency **50** Hz
 Connection **Δ / Y**
 Amps full load **3,09 / 1,79** A
 Amps no-load_(400V) **1,33** A
 Enclosure **IP 55**
 Insulation Class **F (temp. rise B (80 K))**

Max. coolant temp. **40°C**
 Max. altitude **1.000** mtr, above sea level
 Comment
 Cable entries **2 x M25*1,5**

Feature **Alumimium motor**
 Weight **8,3** kg
 Catalog no. **18122075D**
 Warranty **12~18 months**

Efficiency class **N/A**
 Load data 100% 75% 50% 25%
 Efficiency **76,5 74,4 68,9 54,4** %
 Power factor **0,79 0,69 0,55 0,37**

Sound pressure level (1m) **60,8** dB(A)
 Resistance R₂₀ (open) **8,2** Ω
 Resistance R₂₀ **Y 16,5** Ω

Full load torque **2,49** Nm
 DOL Starting torque vs FL torque **3,29**
 DOL Pull up torque vs FL torque **1,97**
 DOL Pull out torque vs FL torque **3,45**
 Star-Delta Starting torque vs FL torque **Y - motor**
 Star-Delta Pull up torque vs FL torque **Y - motor**
 Star-Delta Pull out torque vs FL torque **Y - motor**
 DOL Starting current vs FL current **6,85**
 Star Delta Starting current vs FL current **Y - motor**
 Rotor Inertia **0,000916** kgm²

Bearing DE **6204 - ZZ**
 Bearing NDE **6204 - ZZ**

Extras / Options :

WI	Change	date	sign.
Dutchi Motors B.V. P.O. Box 5390 NL-6802 EJ ARNHEM Tel : +31-(0)26 - 3541 600 Fax : +31-(0)26 - 3541 650		Description	date
		Drawing made by :	19-04-04
		dutchi.motors@dutchi.nl www.dutchi.com	

Power is our commodity, the world is our market !

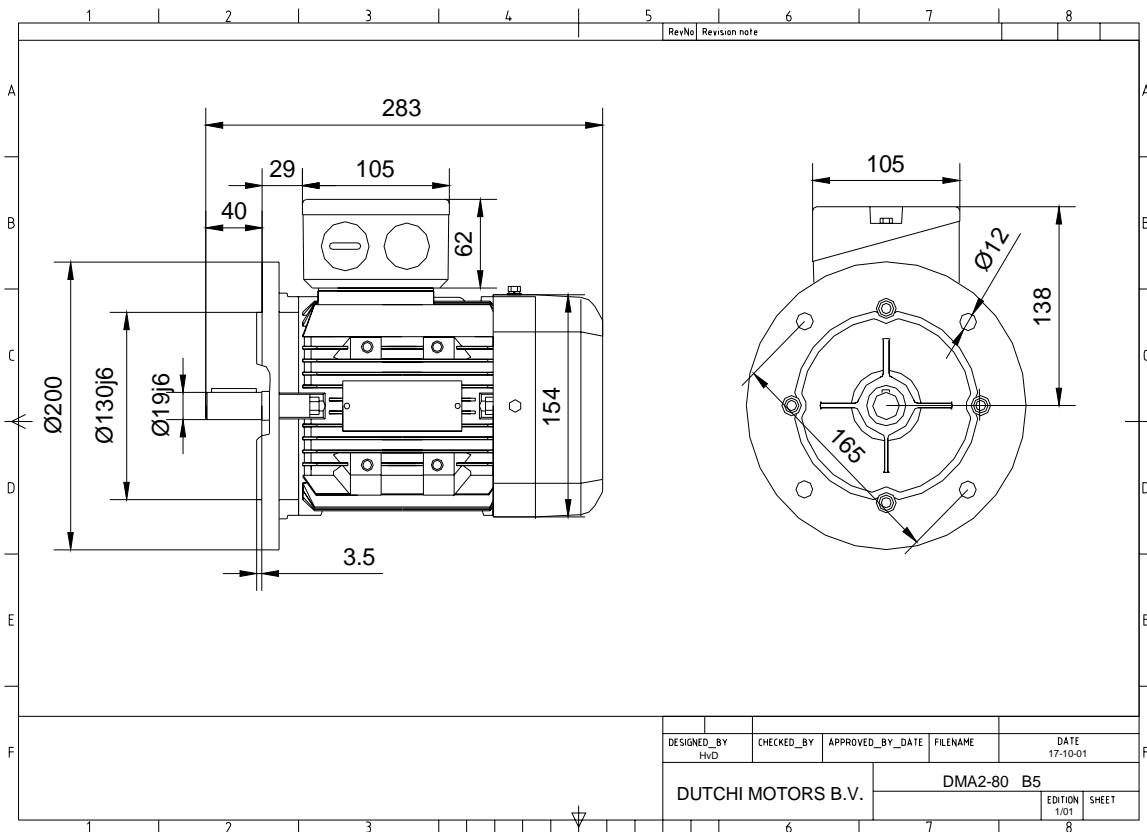

Specification **IEC 60034-1**
 Manufacturer **Dutchi Motors B.V.**
 Motor type **DMA2- 80 K2**
 Rated power **0,75** kW **S1** duty
 Speed **2875** r.p.m
 Voltage **230** / **400 V**
 Frequency **50** Hz
 Connection **Δ / Y**
 Amps full load **3,09** / **1,79** A
 Amps no-load(400V) **1,33** A
 Enclosure **IP 55**
 Insulation Class **F (temp. rise B (80 K))**

Max. coolant temp. **40°C**
 Max. altitude **1.000** mtr, above sea level
 Comment
 Cable entries **2 x M25*1,5**

Feature **Alumimium motor**
 Weight **8,3** kg
 Catalog no. **18222075D**
 Warranty **12~18 months**

Efficiency class **N/A**
 Load data 100% 75% 50% 25%
 Efficiency **76,5 74,4 68,9 54,4** %
 Power factor **0,79 0,69 0,55 0,37**

Sound pressure level (1m) **60,8** dB(A)
 Resistance R20 (open) **8,2** Ω
 Resistance R20 **Y 16,5** Ω

Full load torque **2,49** Nm
 DOL Starting torque vs FL torque **3,29**
 DOL Pull up torque vs FL torque **1,97**
 DOL Pull out torque vs FL torque **3,45**
 Star-Delta Starting torque vs FL torque **Y - motor**
 Star-Delta Pull up torque vs FL torque **Y - motor**
 Star-Delta Pull out torque vs FL torque **Y - motor**
 DOL Starting current vs FL current **6,85**
 Star Delta Starting current vs FL current **Y - motor**
 Rotor Inertia **0,000916** kgm2

Bearing DE **6204 - ZZ**
 Bearing NDE **6204 - ZZ**

Extras / Options :

WI	Change	date	sign.
Dutchi Motors B.V.		Description	date
P.O. Box 5390		Drawing made by :	19-04-04
NL-6802 EJ ARNHEM			
Tel : +31-(0)26 - 3541 600		dutchi.motors@dutchi.nl	
Fax : +31-(0)26 - 3541 650		www.dutchi.com	