

Power is our commodity, the world is our market !

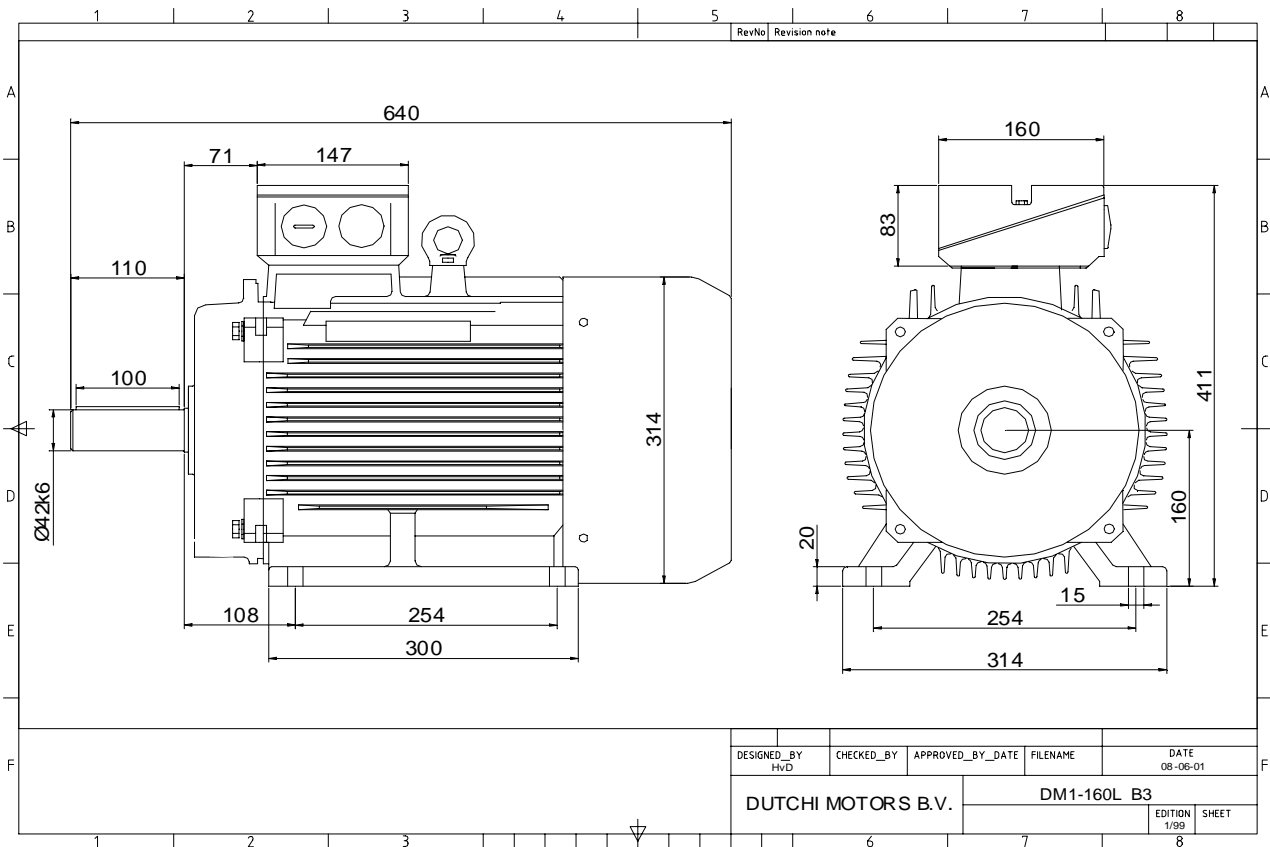

Specification **IEC 60034-1**
 Manufacturer **Dutchi Motors B.V.**
 Motor type **DM1- 160 L4**
 Rated power **15,00** kW **S1** duty
 Speed **1460** r.p.m
 Voltage **400 / 690** V
 Frequency **50** Hz
 Connection **Δ / Y**
 Amps full load **28,2 / 16,3** A
 Amps no-load(400V) **11,02** A
 Enclosure **IP 55**
 Insulation Class **F (temp. rise B (80 K))**

Max. coolant temp. **40°C**
 Max. altitude **1.000** mtr, above sea level
 Comment **3 x PTC 150°C**
 Cable entries **2 x M40x1,5 + 1 x M20x1,5 (ptc)**

Feature **Cast-iron motor**
 Weight **133** kg
 Catalog no. **11134A15D**
 Warranty **12~18 months**

Efficiency class **EFF 2**
 Load data 100% 75% 50% 25%
 Efficiency **89,9 90,3 89,5 84,5** %
 Power factor **0,85 0,81 0,71 0,51**

Sound pressure level (1m) **60,2** dB(A)
 Resistance R20 (open) **0,605** Ω
 Resistance R20 **Δ 0,403** Ω

Full load torque **98** Nm
 DOL Starting torque vs FL torque **2,28**
 DOL Pull up torque vs FL torque **1,64**
 DOL Pull out torque vs FL torque **3,11**
 Star-Delta Starting torque vs FL torque **0,71**
 Star-Delta Pull up torque vs FL torque **0,51**
 Star-Delta Pull out torque vs FL torque **0,97**
 DOL Starting current vs FL current **7,43**
 Star Delta Starting current vs FL current **2,32**
 Rotor Inertia **0,0929** kgm²

Bearing DE **6309 - ZZ C3**
 Bearing NDE **6309 - ZZ C3**

WI	Change	date	sign.
Dutchi Motors B.V.		Description	date
P.O. Box 5390		Drawing made by :	27-04-04
NL-6802 EJ ARNHEM			
Tel : +31-(0)26 - 3541 600		dutchi.motors@dutchi.nl	
Fax : +31-(0)26 - 3541 650		www.dutchi.com	

Power is our commodity, the world is our market !

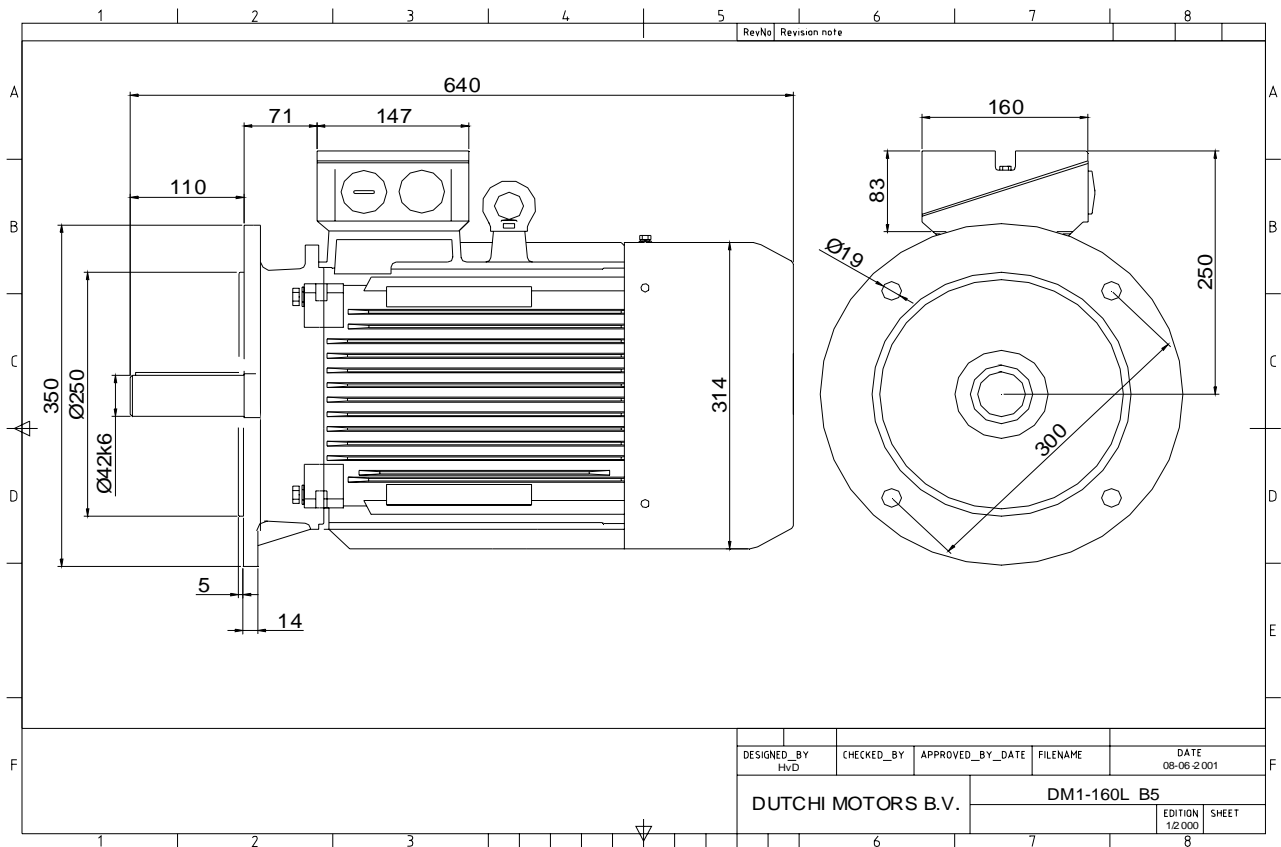

Specification	IEC 60034-1
Manufacturer	Dutchi Motors B.V.
Motor type	DM1- 160 L4
Rated power	15,00 kW S1 duty
Speed	1460 r.p.m
Voltage	400 / 690 V
Frequency	50 Hz
Connection	Δ / Y
Amps full load	28,21 / 16,29 A
Amps no-load(400V)	11,02 A
Enclosure	IP 55
Insulation Class	F (temp. rise B (80 K))
Max. coolant temp.	40°C
Max. altitude	1.000 mtr, above sea level
Comment	3 x PTC 150°C
Cable entries	2 x M40x1,5 + 1 x M20x1,5 (ptc)
Feature	Cast-iron motor
Weight	133 kg
Catalog no.	11234A15D
Warranty	12~18 months

Efficiency class	EFF 2			
Load data	100%	75%	50%	25%
Efficiency	89,9	90,3	89,5	84,5 %
Power factor	0,85	0,81	0,71	0,51
Sound pressure level (1m)				60,2 dB(A)
Resistance R20 (open)				0,605 Ω
Resistance R20	Δ			0,403 Ω
Full load torque				98,12 Nm
DOL Starting torque vs FL torque				2,28
DOL Pull up torque vs FL torque				1,64
DOL Pull out torque vs FL torque				3,11
Star-Delta Starting torque vs FL torque				0,71
Star-Delta Pull up torque vs FL torque				0,51
Star-Delta Pull out torque vs FL torque				0,97
DOL Starting current vs FL current				7,43
Star Delta Starting current vs FL current				2,32
Rotor Inertia				0,0929 kgm ²
Bearing DE				6309 - ZZ C3
Bearing NDE				6309 - ZZ C3

WI	Change	date	sign.
Dutchi Motors B.V. P.O. Box 5390 NL-6802 EJ ARNHEM Tel : +31-(0)26 - 3541 600 Fax : +31-(0)26 - 3541 650		Discription Drawing made by :	date 19-04-04 sign. HvD
dutchi.motors@dutchi.nl www.dutchi.com			