

Power is our commodity, the world is our market !

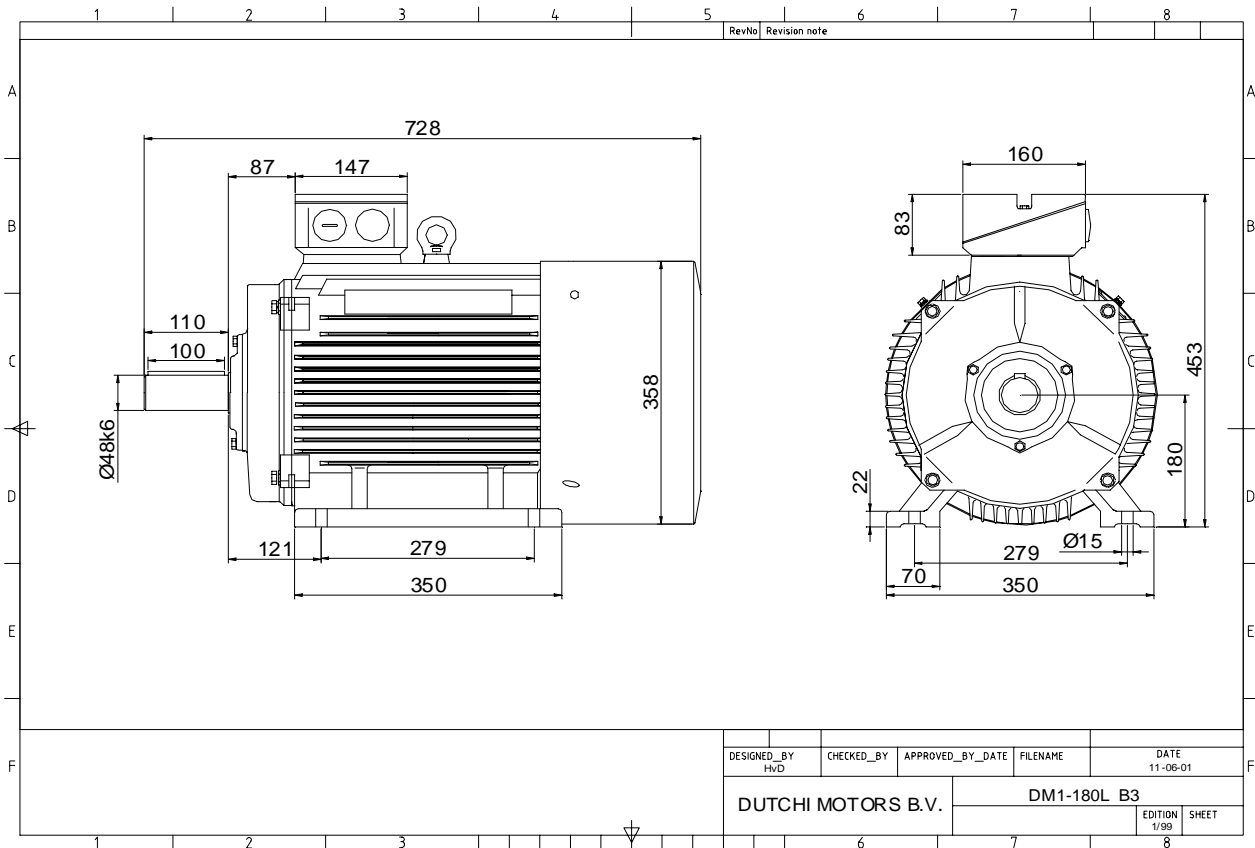

Specification **IEC 60034-1**
 Manufacturer **Dutchi Motors B.V.**
 Motor type **DM1- 180 L6**
 Rated power **15** kW **S1** duty
 Speed **975** r.p.m
 Voltage **400 / 690** V
 Frequency **50** Hz
 Connection **Δ / Y**
 Amps full load **29,4 / 17,0** A
 Amps no-load(400V) **13,30** A
 Enclosure **IP 55**
 Insulation Class **F (temp. rise B (80 K))**

Max. coolant temp. **40°C**
 Max. altitude **1.000** mtr, above sea level
 Comment **3 x PTC 150°C**
 Cable entries **2 x M40x1,5 + 1 x M20x1,5 (ptc)**

Feature **Cast-iron motor**
 Weight **171** kg
 Catalog no. **11136A15D**
 Warranty **12~18 months**

Efficiency class **N/A**
 Load data 100% 75% 50% 25%
 Efficiency **89,0 89,2 87,4 80,8** %
 Power factor **0,83 0,79 0,67 0,45**

Sound pressure level (1m) **60,7** dB(A)
 Resistance R20 (open) **0,709** Ω
 Resistance R20 **Δ 0,473** Ω

Full load torque **146,92** Nm
 DOL Starting torque vs FL torque **2,08**
 DOL Pull up torque vs FL torque **1,51**
 DOL Pull out torque vs FL torque **2,97**
 Star-Delta Starting torque vs FL torque **0,65**
 Star-Delta Pull up torque vs FL torque **0,47**
 Star-Delta Pull out torque vs FL torque **0,93**
 DOL Starting current vs FL current **6,53**
 Star Delta Starting current vs FL current **2,04**
 Rotor Inertia **0,1670** kgm²

Bearing DE **6311 - ZZ C3**
 Bearing NDE **6311 - ZZ C3**

WI	Change	date	sign.
Dutchi Motors B.V.		Discription	date
P.O. Box 5390		Drawing made by :	27-04-04
NL-6802 EJ ARNHEM			
Tel : +31-(0)26 - 3541 600		dutchi.motors@dutchi.nl	
Fax : +31-(0)26 - 3541 650		www.dutchi.com	

Power is our commodity, the world is our market !

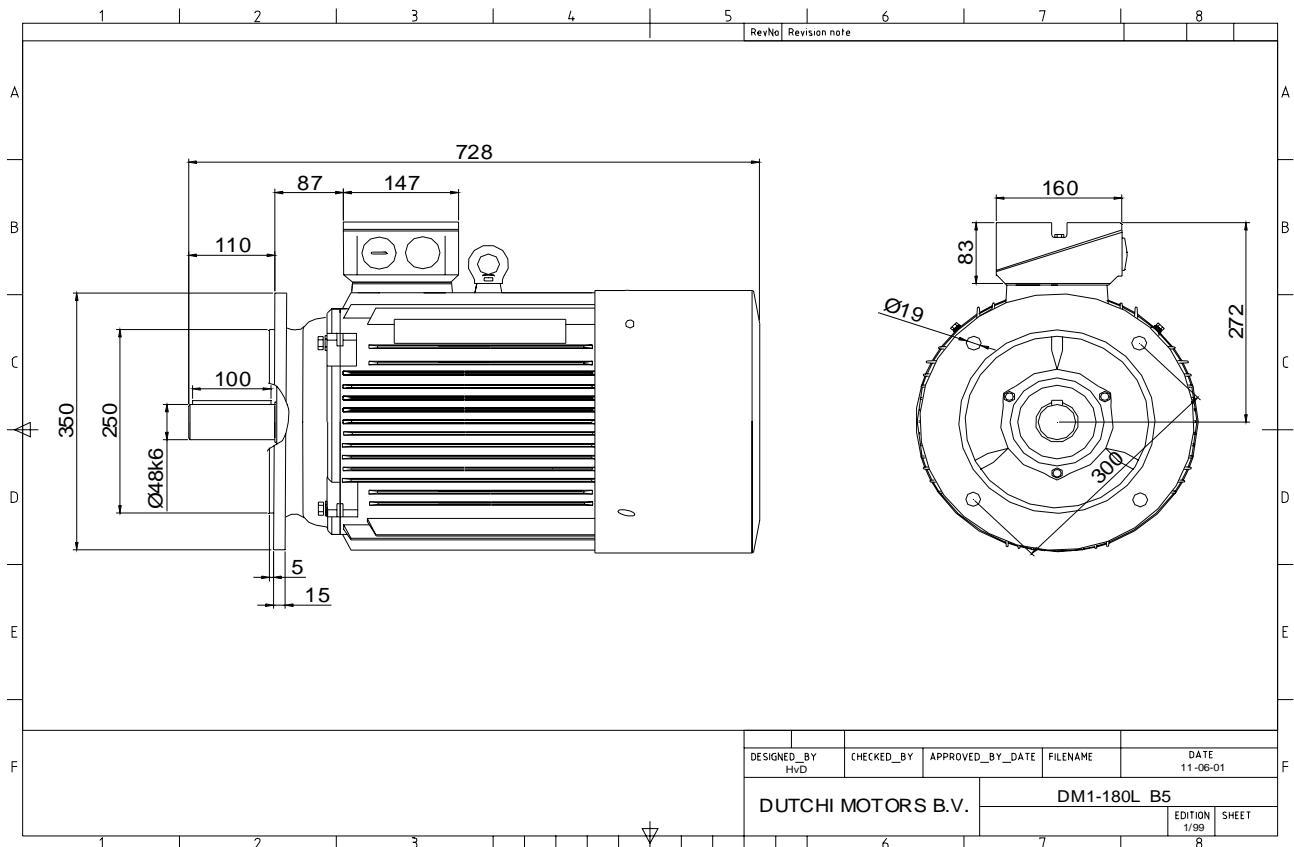

Specification	IEC 60034-1
Manufacturer	Dutchi Motors B.V.
Motor type	DM1- 180 L6
Rated power	15 kW S1 duty
Speed	975 r.p.m
Voltage	400 / 690 V
Frequency	50 Hz
Connection	Δ / Y
Amps full load	29,4 / 17,0 A
Amps no-load(400V)	13,30 A
Enclosure	IP 55
Insulation Class	F (temp. rise B (80 K))
Max. coolant temp.	40°C
Max. altitude	1.000 mtr, above sea level
Comment	3 x PTC 150°C
Cable entries	2 x M40x1,5 + 1 x M20x1,5 (ptc)
Feature	Cast-iron motor
Weight	171 kg
Catalog no.	11236A15D
Warranty	12~18 months

Efficiency class	N/A			
Load data	100%	75%	50%	25%
Efficiency	89,0	89,2	87,4	80,8 %
Power factor	0,83	0,79	0,67	0,45
Sound pressure level (1m)				60,7 dB(A)
Resistance R20 (open)				0,709 Ω
Resistance R20	Δ			0,473 Ω
Full load torque				146,92 Nm
DOL Starting torque vs FL torque				2,08
DOL Pull up torque vs FL torque				1,51
DOL Pull out torque vs FL torque				2,97
Star-Delta Starting torque vs FL torque				0,65
Star-Delta Pull up torque vs FL torque				0,47
Star-Delta Pull out torque vs FL torque				0,93
DOL Starting current vs FL current				6,53
Star Delta Starting current vs FL current				2,04
Rotor Inertia				0,1670 kgm ²
Bearing DE				6311 - ZZ C3
Bearing NDE				6311 - ZZ C3

WI	Change	date	sign.
Dutchi Motors B.V. P.O. Box 5390 NL-6802 EJ ARNHEM Tel : +31-(0)26 - 3541 600 Fax : +31-(0)26 - 3541 650		Discription Drawing made by :	date sign. HvD
		27-04-04	
		dutchi.motors@dutchi.nl www.dutchi.com	