

Power is our commodity, the world is our market !

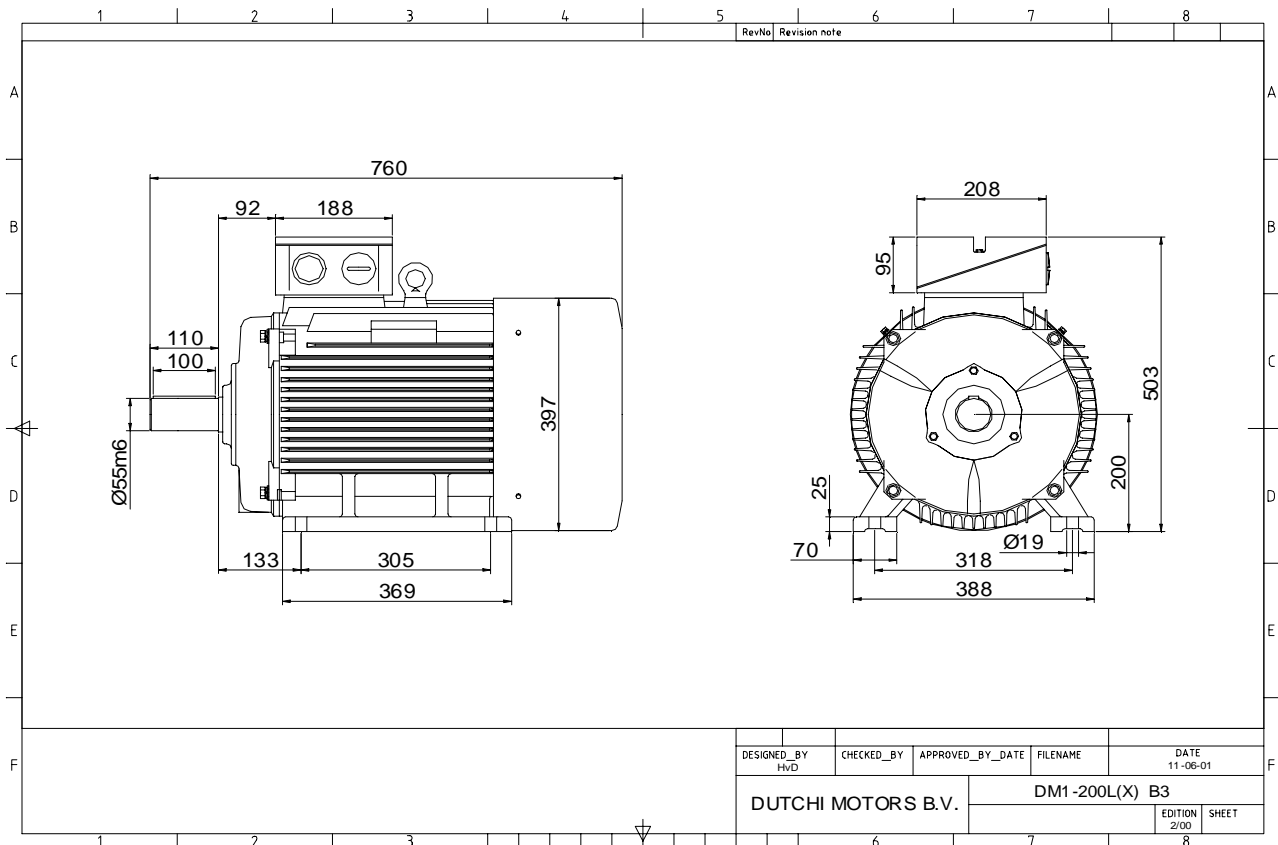

Specification	IEC 60034-1
Manufacturer	Dutchi Motors B.V.
Motor type	DM1- 200 LX6
Rated power	22 kW S1 duty
Speed	975 r.p.m
Voltage	400 / 690 V
Frequency	50 Hz
Connection	Δ / Y
Amps full load	41,6 / 24,0 A
Amps no-load(400V)	15,90 A
Enclosure	IP 55
Insulation Class	F (temp. rise B (80 K))
Max. coolant temp.	40°C
Max. altitude	1.000 mtr, above sea level
Comment	3 x PTC 150°C
Cable entries	2 x M50x1,5 + 1 x M20x1,5 (ptc)
Feature	Cast-iron motor
Weight	225 kg
Catalog no.	11136A22D
Warranty	12~18 months

Efficiency class	N/A			
Load data	100%	75%	50%	25%
Efficiency	90,0	90,2	89,0	83,3 %
Power factor	0,85	0,81	0,72	0,50
Sound pressure level (1m)				64,3 dB(A)
Resistance R20 (open)				0,431 Ω
Resistance R20	Δ			0,288 Ω
Full load torque				215,49 Nm
DOL Starting torque vs FL torque				2,11
DOL Pull up torque vs FL torque				1,57
DOL Pull out torque vs FL torque				3,07
Star-Delta Starting torque vs FL torque				0,66
Star-Delta Pull up torque vs FL torque				0,49
Star-Delta Pull out torque vs FL torque				0,96
DOL Starting current vs FL current				6,75
Star Delta Starting current vs FL current				2,11
Rotor Inertia				0,3420 kgm ²
Bearing DE				6312 - ZZ C3
Bearing NDE				6312 - ZZ C3

WI	Change	date	sign.
Dutchi Motors B.V. P.O. Box 5390 NL-6802 EJ ARNHEM Tel : +31-(0)26 - 3541 600 Fax : +31-(0)26 - 3541 650		Description	date
		Drawing made by :	27-04-04
		dutchi.motors@dutchi.nl www.dutchi.com	

Power is our commodity, the world is our market !

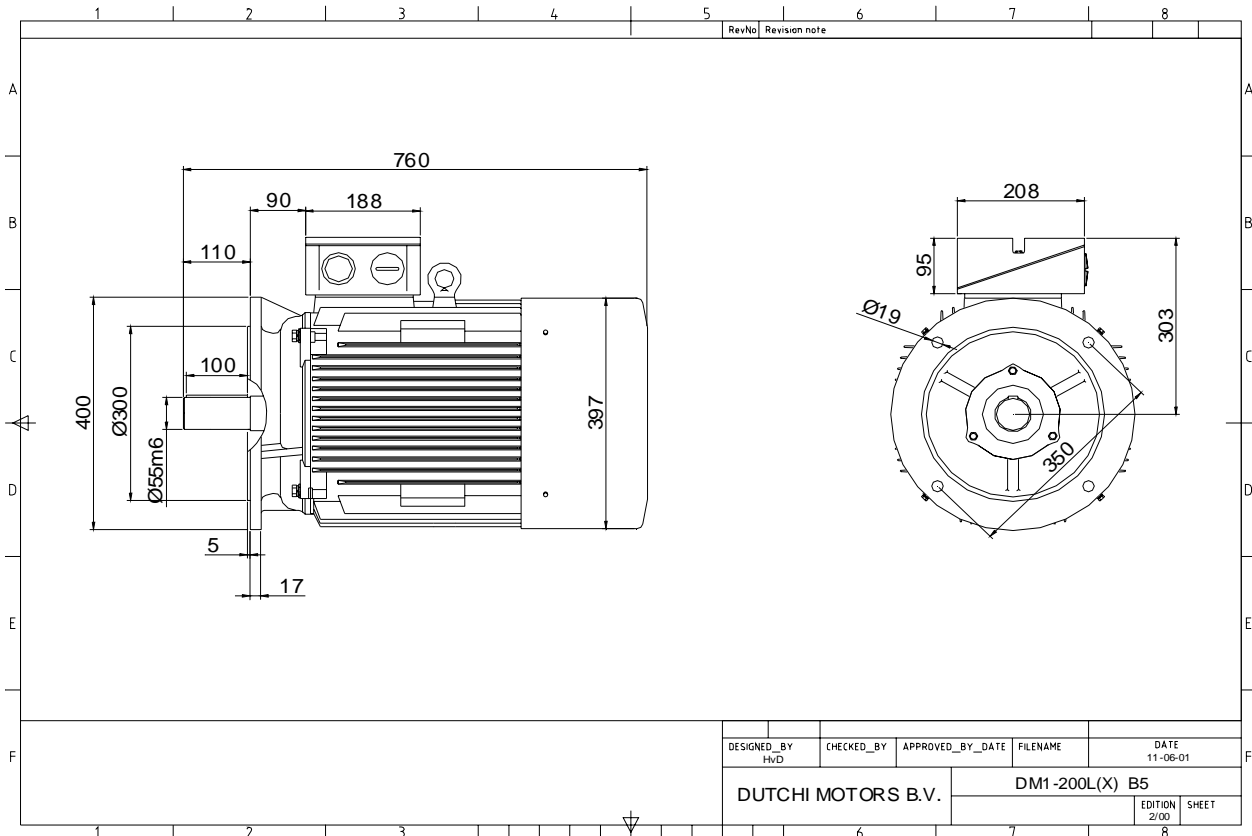

Specification **IEC 60034-1**
 Manufacturer **Dutchi Motors B.V.**
 Motor type **DM1- 200 LX6**
 Rated power **22** kW **S1** duty
 Speed **975** r.p.m
 Voltage **400 / 690** V
 Frequency **50** Hz
 Connection **Δ / Y**
 Amps full load **41,6 / 24,0** A
 Amps no-load(400V) **15,90** A
 Enclosure **IP 55**
 Insulation Class **F (temp. rise B (80 K))**

Max. coolant temp. **40°C**
 Max. altitude **1.000** mtr, above sea level
 Comment **3 x PTC 150°C**
 Cable entries **2 x M50x1,5 + 1 x M20x1,5 (ptc)**

Feature **Cast-iron motor**
 Weight **225** kg
 Catalog no. **11236A22D**
 Warranty **12~18 months**

Efficiency class **N/A**
 Load data 100% 75% 50% 25%
 Efficiency **90,0 90,2 89,0 83,3** %
 Power factor **0,85 0,81 0,72 0,50**

Sound pressure level (1m) **64,3** dB(A)
 Resistance R20 (open) **0,431** Ω
 Resistance R20 **Δ 0,288** Ω

Full load torque **215,49** Nm
 DOL Starting torque vs FL torque **2,11**
 DOL Pull up torque vs FL torque **1,57**
 DOL Pull out torque vs FL torque **3,07**
 Star-Delta Starting torque vs FL torque **0,66**
 Star-Delta Pull up torque vs FL torque **0,49**
 Star-Delta Pull out torque vs FL torque **0,96**
 DOL Starting current vs FL current **6,75**
 Star Delta Starting current vs FL current **2,11**
 Rotor Inertia **0,3420** kgm²

Bearing DE **6312 - ZZ C3**
 Bearing NDE **6312 - ZZ C3**

WI	Change	date	sign.
Dutchi Motors B.V.		Discription	date
P.O. Box 5390		Drawing made by :	27-04-04
NL-6802 EJ ARNHEM			
Tel : +31-(0)26 - 3541 600		dutchi.motors@dutchi.nl	
Fax : +31-(0)26 - 3541 650		www.dutchi.com	