

Power is our commodity, the world is our market !

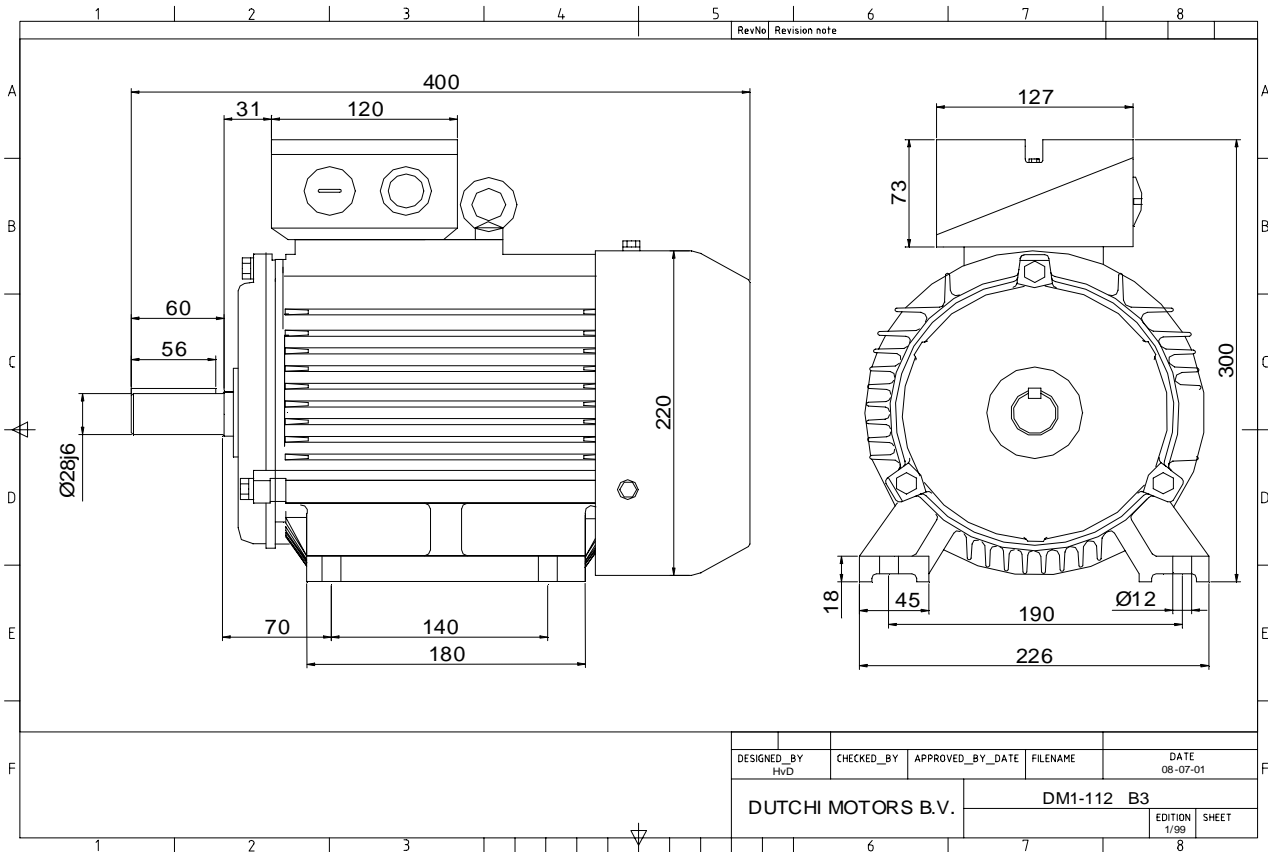

Specification	IEC 60034-1
Manufacturer	Dutchi Motors B.V.
Motor type	DM1- 112 M4
Rated power	4 kW S1 duty
Speed	1430 r.p.m
Voltage	400 / 690 V
Frequency	50 Hz
Connection	Δ / Y
Amps full load	8,28 / 4,78 A
Amps no-load(400V)	4,00 A
Enclosure	IP 55
Insulation Class	F (temp. rise B (80 K))
Max. coolant temp.	40°C
Max. altitude	1.000 mtr, above sea level
Comment	3 x PTC 150°C
Cable entries	2 x M32x1,5 + 1 x M20x1,5 (ptc)
Feature	Cast-iron motor
Weight	44,0 kg
Catalog no.	11134400D
Warranty	12~18 months

Efficiency class	EFF 2			
Load data	100%	75%	50%	25%
Efficiency	84,4	85,0	83,8	76,9 %
Power factor	0,83	0,76	0,63	0,44
Sound pressure level (1m)				54,0 dB(A)
Resistance R20 (open)				4,34 Ω
Resistance R20	Δ			2,89 Ω
Full load torque				26,71 Nm
DOL Starting torque vs FL torque				2,37
DOL Pull up torque vs FL torque				1,69
DOL Pull out torque vs FL torque				3,20
Star-Delta Starting torque vs FL torque				0,74
Star-Delta Pull up torque vs FL torque				0,53
Star-Delta Pull out torque vs FL torque				1,00
DOL Starting current vs FL current				6,79
Star Delta Starting current vs FL current				2,12
Rotor Inertia				0,0086 kgm ²
Bearing DE				6306 - ZZ C3
Bearing NDE				6306 - ZZ C3

WI	Change	date	sign.
Dutchi Motors B.V. P.O. Box 5390 NL-6802 EJ ARNHEM Tel : +31-(0)26 - 3541 600 Fax : +31-(0)26 - 3541 650		Discription Drawing made by :	date sign. HvD
dutchi.motors@dutchi.nl www.dutchi.com		19-04-04	

Power is our commodity, the world is our market !

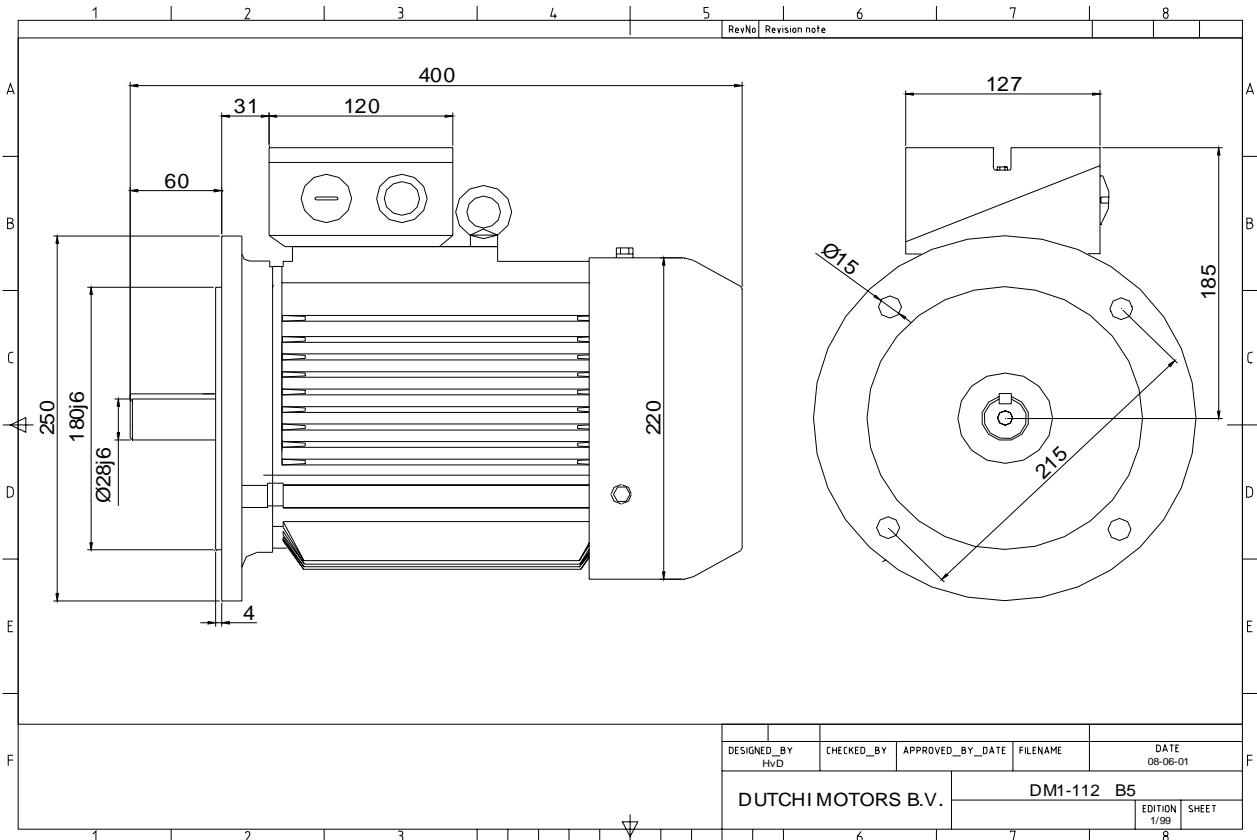

Specification **IEC 60034-1**
 Manufacturer **Dutchi Motors B.V.**
 Motor type **DM1- 112 M4**
 Rated power **4** kW **S1** duty
 Speed **1430** r.p.m
 Voltage **400** / **690** V
 Frequency **50** Hz
 Connection **Δ** / **Y**
 Amps full load **8,28** / **4,78** A
 Amps no-load(400V) **4,00** A
 Enclosure **IP 55**
 Insulation Class **F (temp. rise B (80 K))**

Max. coolant temp. **40°C**
 Max. altitude **1.000** mtr, above sea level
 Comment **3 x PTC 150°C**
 Cable entries **2 x M32x1,5 + 1 x M20x1,5 (ptc)**

Feature **Cast-iron motor**
 Weight **44,0** kg
 Catalog no. **11234400D**
 Warranty **12~18 months**

Efficiency class **EFF 2**
 Load data 100% 75% 50% 25%
 Efficiency **84,4 85,0 83,8 76,9** %
 Power factor **0,83 0,76 0,63 0,44**

Sound pressure level (1m) **54,0** dB(A)
 Resistance R20 (open) **4,34** Ω
 Resistance R20 **Δ 2,89** Ω

Full load torque **26,71** Nm
 DOL Starting torque vs FL torque **2,37**
 DOL Pull up torque vs FL torque **1,69**
 DOL Pull out torque vs FL torque **3,20**
 Star-Delta Starting torque vs FL torque **0,74**
 Star-Delta Pull up torque vs FL torque **0,53**
 Star-Delta Pull out torque vs FL torque **1,00**
 DOL Starting current vs FL current **6,79**
 Star Delta Starting current vs FL current **2,12**
 Rotor Inertia **0,0086** kgm²

Bearing DE **6306 - ZZ C3**
 Bearing NDE **6306 - ZZ C3**

WI	Change	date	sign.
Dutchi Motors B.V.		Description	date
P.O. Box 5390		Drawing made by :	19-04-04
NL-6802 EJ ARNHEM			
Tel : +31-(0)26 - 3541 600		dutchi.motors@dutchi.nl	
Fax : +31-(0)26 - 3541 650		www.dutchi.com	