

Power is our commodity, the world is our market !

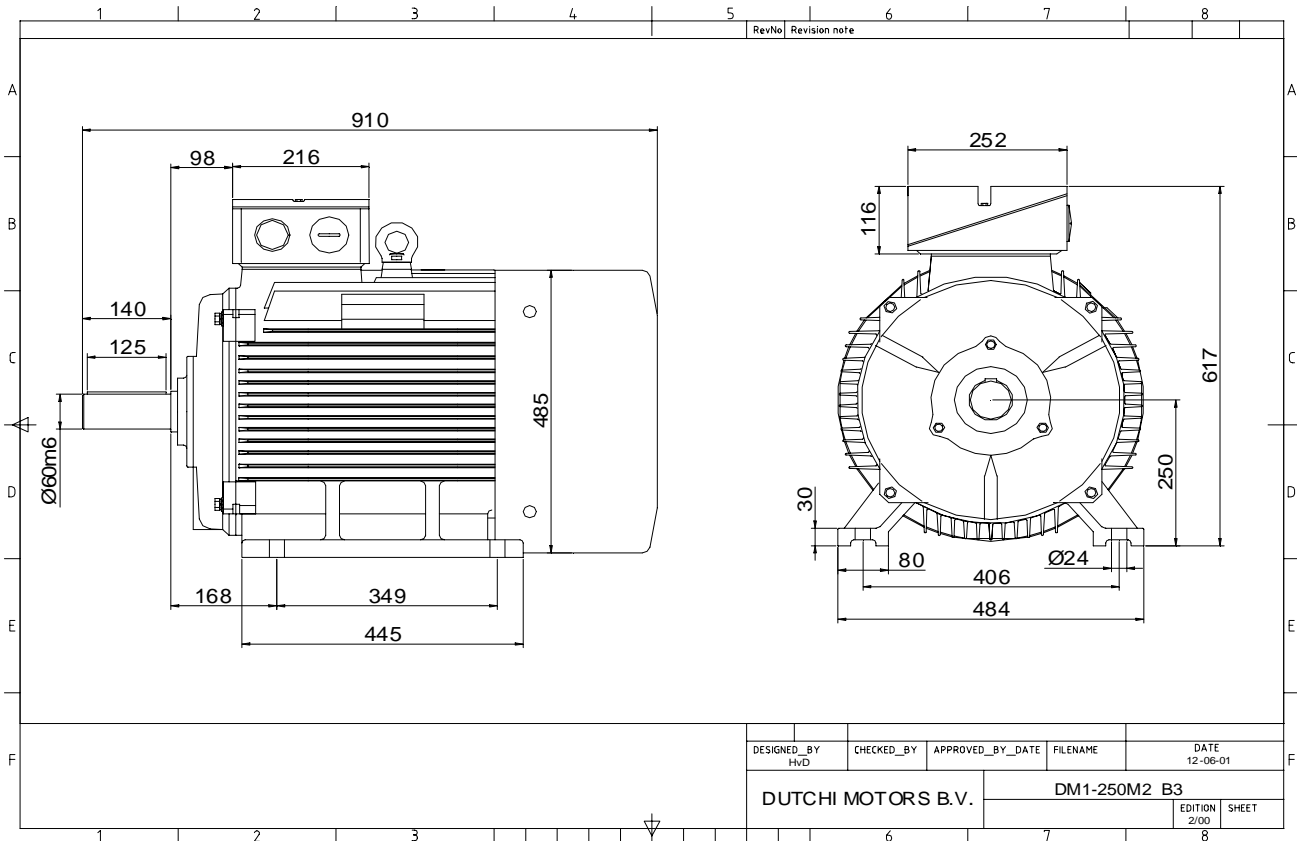

Specification **IEC 60034-1**
 Manufacturer **Dutchi Motors B.V.**
 Motor type **DM1- 250 M2**
 Rated power **55** kW **S1** duty
 Speed **2965** r.p.m
 Voltage **400** / **690** V
 Frequency **50** Hz
 Connection **Δ** / **Y**
 Amps full load **95,1** / **54,9** A
 Amps no-load(400V) **25,50** A
 Enclosure **IP 55**
 Insulation Class **F (temp. rise B (80 K))**

Max. coolant temp. **40°C**
 Max. altitude **1.000** mtr, above sea level
 Comment **3 x PTC 150°C**
 Cable entries **2 x M63x1,5 + 1 x M20x1,5 (ptc)**

Feature **Cast-iron motor**
 Weight **377** kg
 Catalog no. **11132A55D**
 Warranty **12~18 months**

Efficiency class **EFF 2**
 Load data 100% 75% 50% 25%
 Efficiency **93,0 92,4 90,7 84,7** %
 Power factor **0,90 0,88 0,83 0,68**

Sound pressure level (1m) **77,7** dB(A)
 Resistance R20 (open) **0,083** Ω
 Resistance R20 **Δ 0,055** Ω

Full load torque **177,15** Nm
 DOL Starting torque vs FL torque **2,26**
 DOL Pull up torque vs FL torque **1,68**
 DOL Pull out torque vs FL torque **3,51**
 Star-Delta Starting torque vs FL torque **0,71**
 Star-Delta Pull up torque vs FL torque **0,53**
 Star-Delta Pull out torque vs FL torque **1,10**
 DOL Starting current vs FL current **7,82**
 Star Delta Starting current vs FL current **2,44**
 Rotor Inertia **0,3050** kgm²

Bearing DE **6314 - ZZ C3**
 Bearing NDE **6314 - ZZ C3**

WI	Change	date	sign.
Dutchi Motors B.V. P.O. Box 5390 NL-6802 EJ ARNHEM Tel : +31-(0)26 - 3541 600 Fax : +31-(0)26 - 3541 650	Description	date	sign.
	Drawing made by :	27-04-04	HvD
	dutchi.motors@dutchi.nl www.dutchi.com		

Power is our commodity, the world is our market !

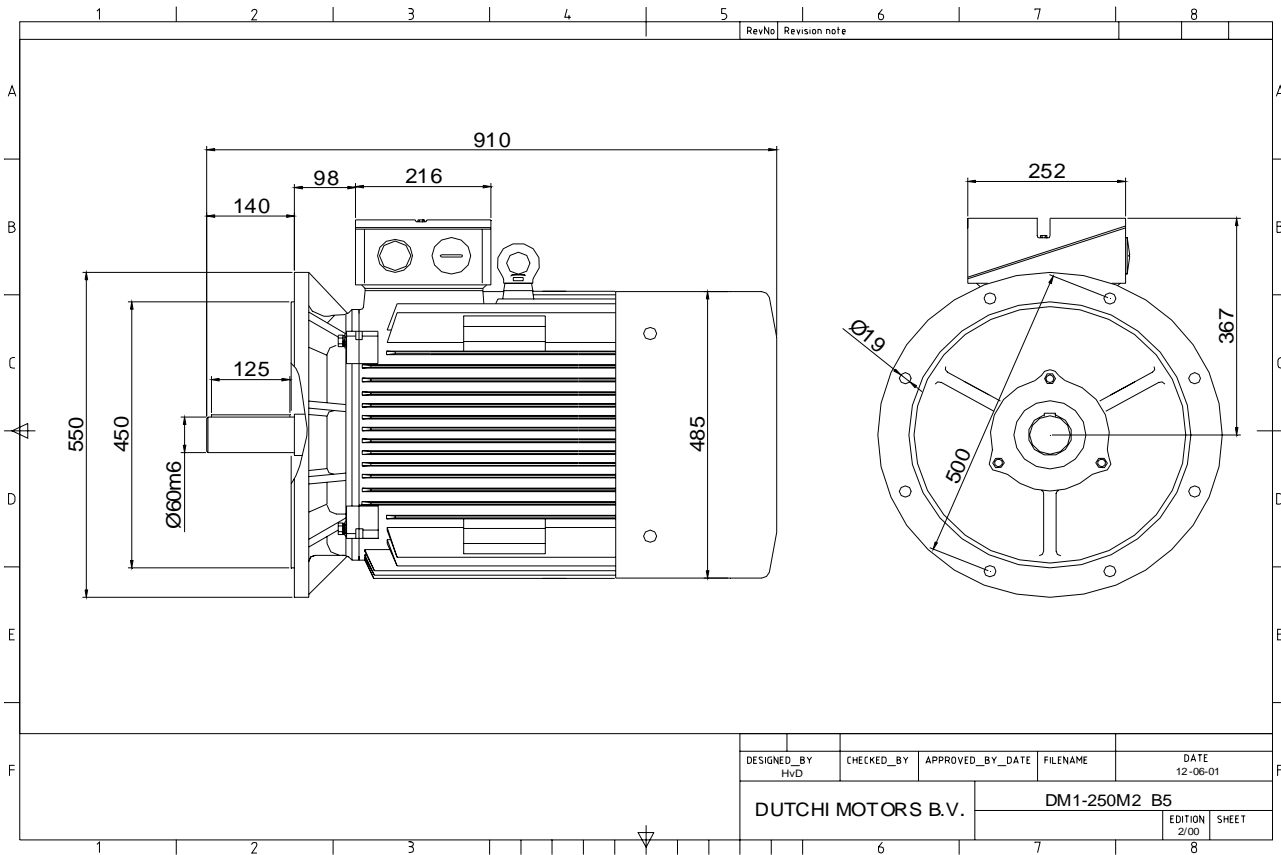

DESIGNED_BY HvD	CHECKED_BY	APPROVED_BY_DATE	FILENAME	DATE 12-06-01
DUTCHI MOTORS B.V.			DM1-250M2 B5	
			EDITION 2/00	SHEET

Specification	IEC 60034-1
Manufacturer	Dutchi Motors B.V.
Motor type	DM1- 250 M2
Rated power	55 kW S1 duty
Speed	2965 r.p.m
Voltage	400 / 690 V
Frequency	50 Hz
Connection	Δ / Y
Amps full load	95,1 / 54,9 A
Amps no-load(400V)	25,50 A
Enclosure	IP 55
Insulation Class	F (temp. rise B (80 K))
Max. coolant temp.	40°C
Max. altitude	1.000 mtr, above sea level
Comment	3 x PTC 150°C
Cable entries	2 x M63x1,5 + 1 x M20x1,5 (ptc)
Feature	Cast-iron motor
Weight	377 kg
Catalog no.	11232A55D
Warranty	12~18 months

Efficiency class	EFF 2			
Load data	100%	75%	50%	25%
Efficiency	93,0	92,4	90,7	84,7 %
Power factor	0,90	0,88	0,83	0,68
Sound pressure level (1m)				77,7 dB(A)
Resistance R20 (open)				0,083 Ω
Resistance R20	Δ			0,055 Ω
Full load torque				177,15 Nm
DOL Starting torque vs FL torque				2,26
DOL Pull up torque vs FL torque				1,68
DOL Pull out torque vs FL torque				3,51
Star-Delta Starting torque vs FL torque				0,71
Star-Delta Pull up torque vs FL torque				0,53
Star-Delta Pull out torque vs FL torque				1,10
DOL Starting current vs FL current				7,82
Star Delta Starting current vs FL current				2,44
Rotor Inertia				0,3050 kgm ²
Bearing DE				6314 - ZZ C3
Bearing NDE				6314 - ZZ C3

WI	Change	date	sign.
Dutchi Motors B.V. P.O. Box 5390 NL-6802 EJ ARNHEM Tel : +31-(0)26 - 3541 600 Fax : +31-(0)26 - 3541 650		Discription Drawing made by :	date 27-04-04 sign. HvD
		dutchi.motors@dutchi.nl www.dutchi.com	