

Power is our commodity, the world is our market !

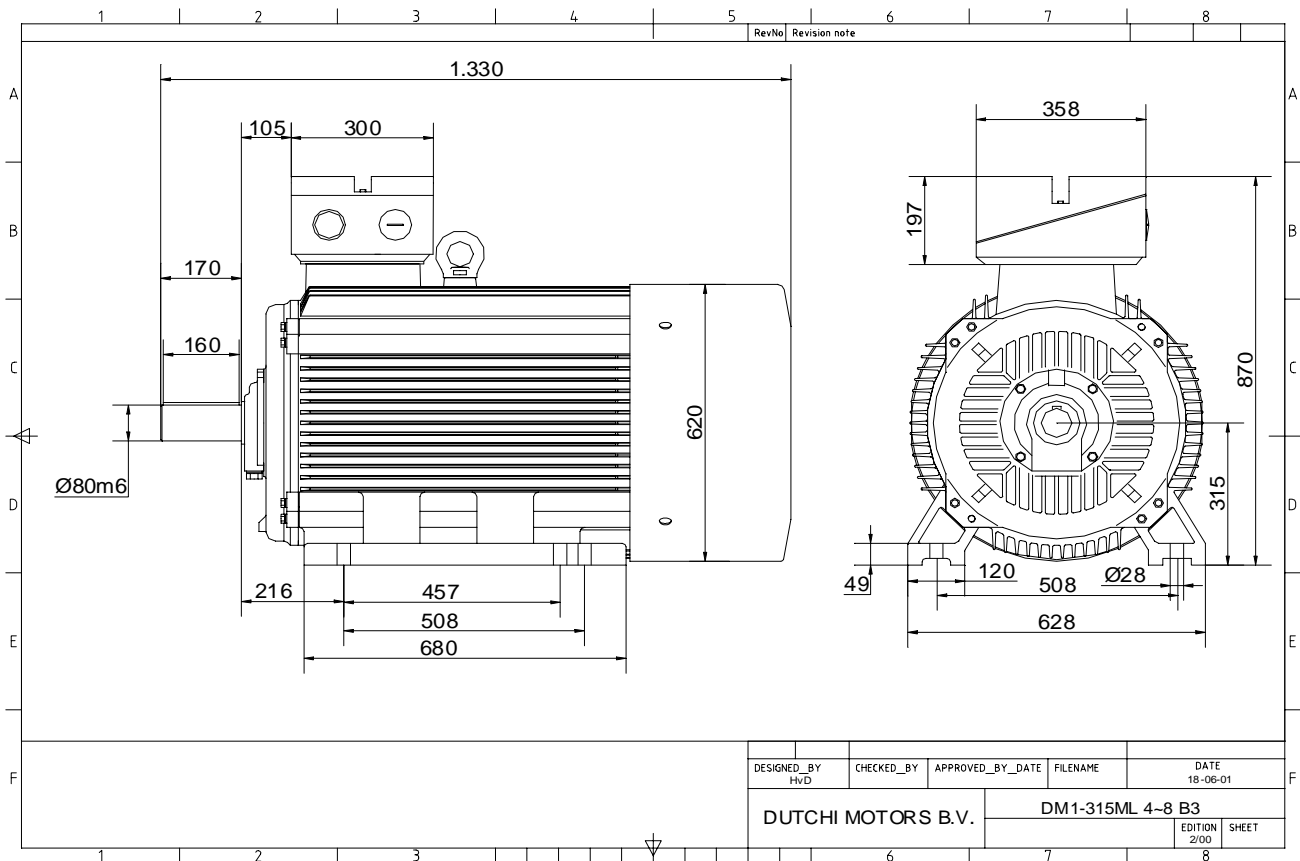

Specification **IEC 60034-1**  
 Manufacturer **Dutchi Motors B.V.**  
 Motor type **DM1- 315 M8**  
 Rated power **75** kW **S1** duty  
 Speed **745** r.p.m  
 Voltage **400 / 690** V  
 Frequency **50** Hz  
 Connection **Δ / Y**  
 Amps full load **142 / 82** A  
 Amps no-load(400V) **56,40** A  
 Enclosure **IP 55**  
 Insulation Class **F (temp. rise B (80 K))**

Max. coolant temp. **40°C**  
 Max. altitude **1.000** mtr, above sea level  
 Comment **3 x PTC 150°C**  
 Cable entries **2 x M63x1,5 + 1 x M20x1,5 (ptc)**

Feature **Cast-iron motor**  
 Weight **981** kg  
 Catalog no. **11138A75D**  
 Warranty **12~18 months**

Efficiency class **N/A**  
 Load data 100% 75% 50% 25%  
 Efficiency **93,3 93,1 91,5 86,1** %  
 Power factor **0,81 0,78 0,68 0,46**

Sound pressure level (1m) **64,0** dB(A)  
 Resistance R20 (open) **0,0585** Ω  
 Resistance R20 **Δ 0,0390** Ω

Full load torque **961** Nm  
 DOL Starting torque vs FL torque **1,99**  
 DOL Pull up torque vs FL torque **1,57**  
 DOL Pull out torque vs FL torque **2,81**  
 Star-Delta Starting torque vs FL torque **0,62**  
 Star-Delta Pull up torque vs FL torque **0,49**  
 Star-Delta Pull out torque vs FL torque **0,88**  
 DOL Starting current vs FL current **6,11**  
 Star Delta Starting current vs FL current **1,91**  
 Rotor Inertia **5,3600** kgm<sup>2</sup>

Bearing DE **6319 - C3 or NU319**  
 Bearing NDE **6319 - C3 (IM V1 7319B)**

WI	Change	date	sign.
<b>Dutchi Motors B.V.</b> P.O. Box 5390 NL-6802 EJ ARNHEM Tel : +31-(0)26 - 3541 600 Fax : +31-(0)26 - 3541 650		Discription Drawing made by : 27-04-04	date sign. HvD
dutchi.motors@dutchi.nl www.dutchi.com			

Power is our commodity, the world is our market !

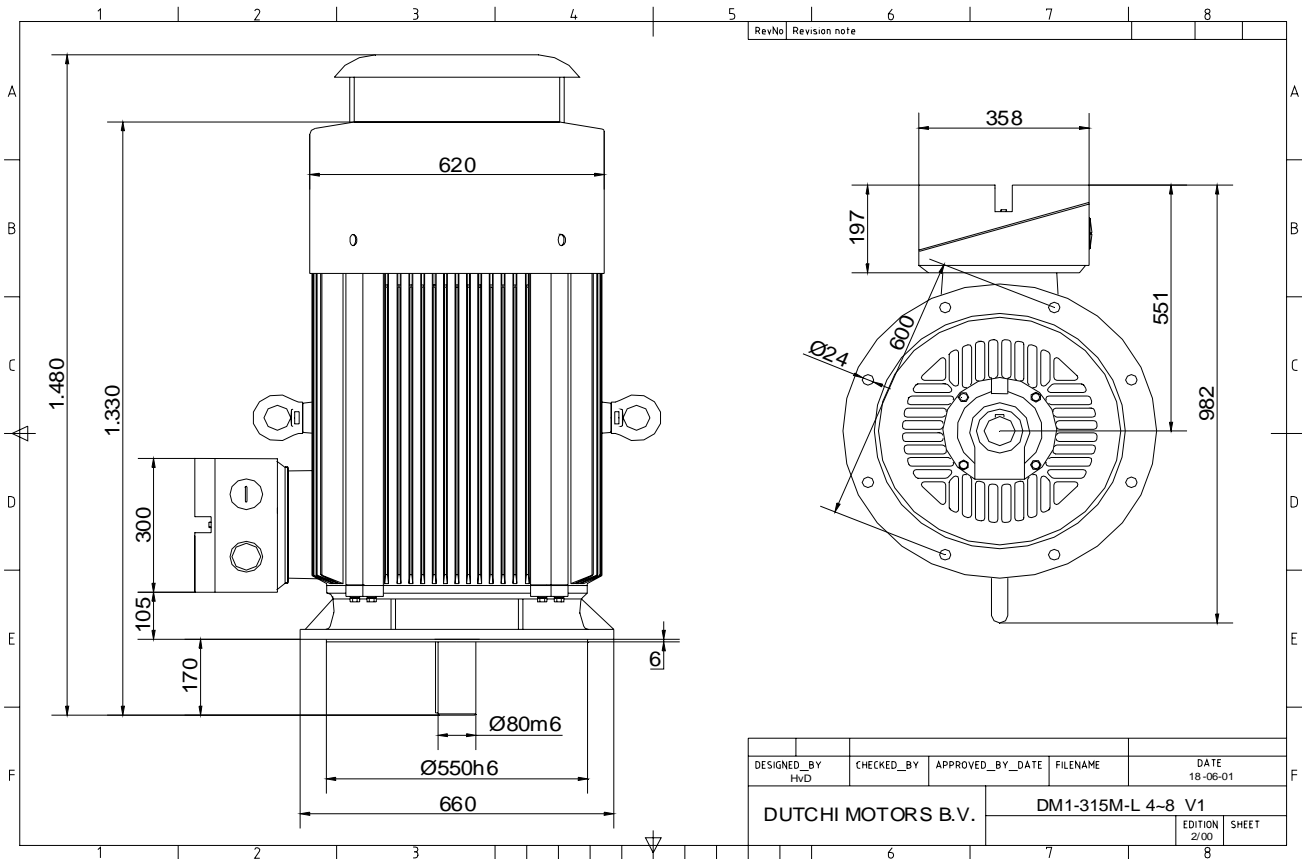

Specification **IEC 60034-1**  
 Manufacturer **Dutchi Motors B.V.**  
 Motor type **DM1- 315 M8**  
 Rated power **75** kW **S1** duty  
 Speed **745** r.p.m  
 Voltage **400** / **690** V  
 Frequency **50** Hz  
 Connection **Δ** / **Y**  
 Amps full load **142** / **82** A  
 Amps no-load(400V) **56,40** A  
 Enclosure **IP 55**  
 Insulation Class **F (temp. rise B (80 K))**

Max. coolant temp. **40°C**  
 Max. altitude **1.000** mtr, above sea level  
 Comment **3 x PTC 150°C**  
 Cable entries **2 x M63x1,5 + 1 x M20x1,5 (ptc)**

Feature **Cast-iron motor**  
 Weight **981** kg  
 Catalog no. **11038A75D**  
 Warranty **12~18 months**

Efficiency class **N/A**  
 Load data 100% 75% 50% 25%  
 Efficiency **93,3 93,1 91,5 86,1** %  
 Power factor **0,81 0,78 0,68 0,46**

Sound pressure level (1m) **64,0** dB(A)  
 Resistance R20 (open) **0,0585** Ω  
 Resistance R20 **Δ 0,0390** Ω

Full load torque **961** Nm  
 DOL Starting torque vs FL torque **1,99**  
 DOL Pull up torque vs FL torque **1,57**  
 DOL Pull out torque vs FL torque **2,81**  
 Star-Delta Starting torque vs FL torque **0,62**  
 Star-Delta Pull up torque vs FL torque **0,49**  
 Star-Delta Pull out torque vs FL torque **0,88**  
 DOL Starting current vs FL current **6,11**  
 Star Delta Starting current vs FL current **1,91**  
 Rotor Inertia **5,3600** kgm<sup>2</sup>

Bearing DE **6319 - C3 or NU319**  
 Bearing NDE **6319 - C3 (IM V1 7319B)**

WI	Change	date	sign.
Dutchi Motors B.V.		Description	date
P.O. Box 5390		Drawing made by :	27-04-04
NL-6802 EJ ARNHEM			
Tel : +31-(0)26 - 3541 600		dutchi.motors@dutchi.nl	
Fax : +31-(0)26 - 3541 650		www.dutchi.com	