

Power is our commodity, the world is our market !

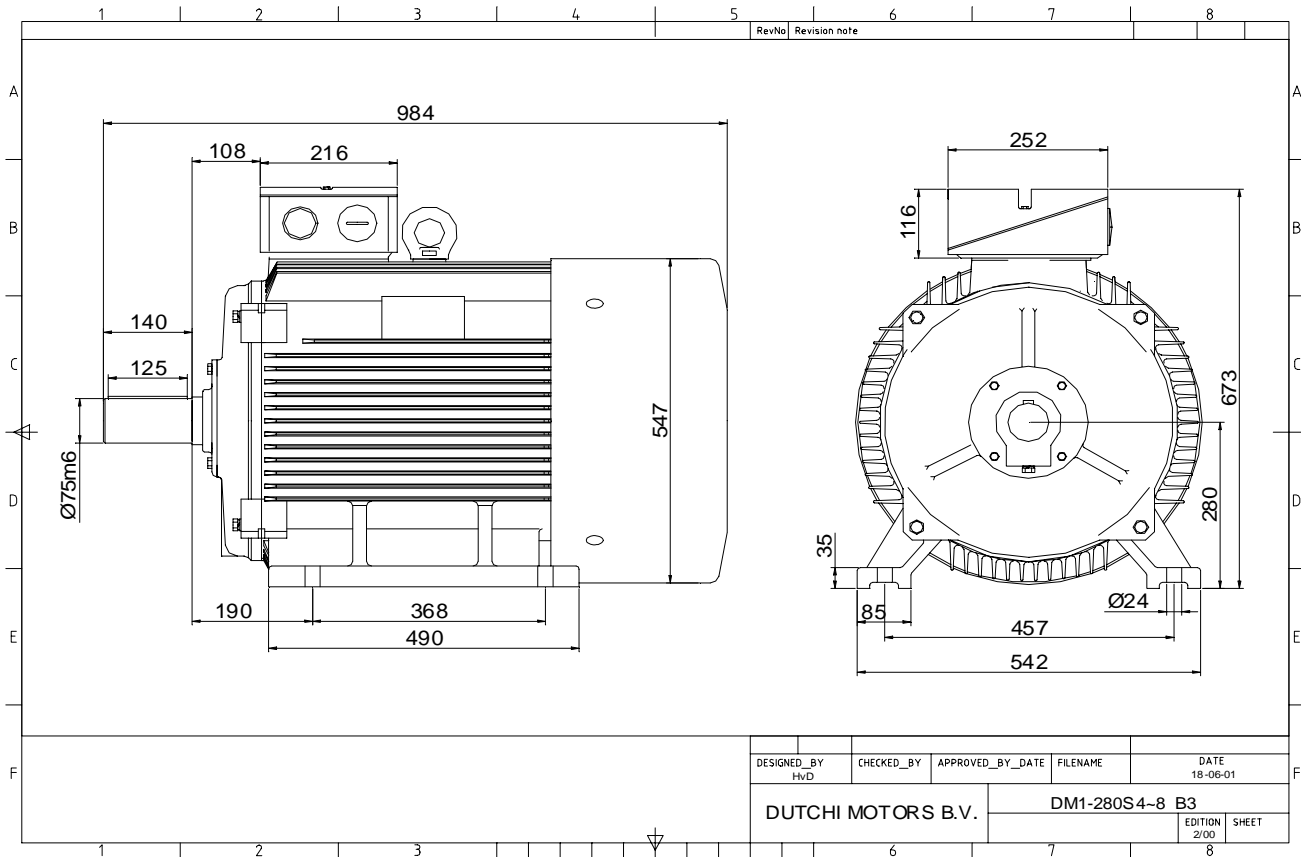

Specification	IEC 60034-1
Manufacturer	Dutchi Motors B.V.
Motor type	DM1-HE 280S4
Rated power	75,0 kW S1 duty
Speed	1486 r.p.m
Voltage	400 / 690 V
Frequency	50 Hz
Connection	Δ / Y
Amps full load	126,5 / 73,0 A
Amps no-load(400V)	33,90 A
Enclosure	IP 55
Insulation Class	F (temp. rise B (80 K))
Max. coolant temp.	40°C
Max. altitude	1.000 mtr, above sea level
Comment	3 x PTC 150°C
Cable entries	2 x M63x1,5 + 1 x M20x1,5 (ptc)
Feature	Cast-iron motor
Weight	kg
Catalog no.	11134A75DH
Warranty	12~18 months

Efficiency class	EFF 1			
Load data	100%	75%	50%	25%
Efficiency	95,0	95,1	94,5	91,4 %
Power factor	0,90	0,88	0,83	0,68
Sound pressure level (1m)				70,4 dB(A)
Resistance R20 (open)				0,063 Ω
Resistance R20	Δ			0,042 Ω
Full load torque				482 Nm
DOL Starting torque vs FL torque				2,05
DOL Pull up torque vs FL torque				1,41
DOL Pull out torque vs FL torque				3,35
Star-Delta Starting torque vs FL torque				0,64
Star-Delta Pull up torque vs FL torque				0,44
Star-Delta Pull out torque vs FL torque				1,05
DOL Starting current vs FL current				7,02
Star Delta Starting current vs FL current				2,19
Rotor Inertia				kgm ²
Bearing DE				6317 - C3
Bearing NDE				6317 - C3

WI	Change	date	sign.
Dutchi Motors B.V.		Description	date
P.O. Box 5390		Drawing made by :	27-04-04
NL-6802 EJ ARNHEM			
Tel : +31-(0)26 - 3541 600		dutchi.motors@dutchi.nl	
Fax : +31-(0)26 - 3541 650		www.dutchi.com	

Power is our commodity, the world is our market !

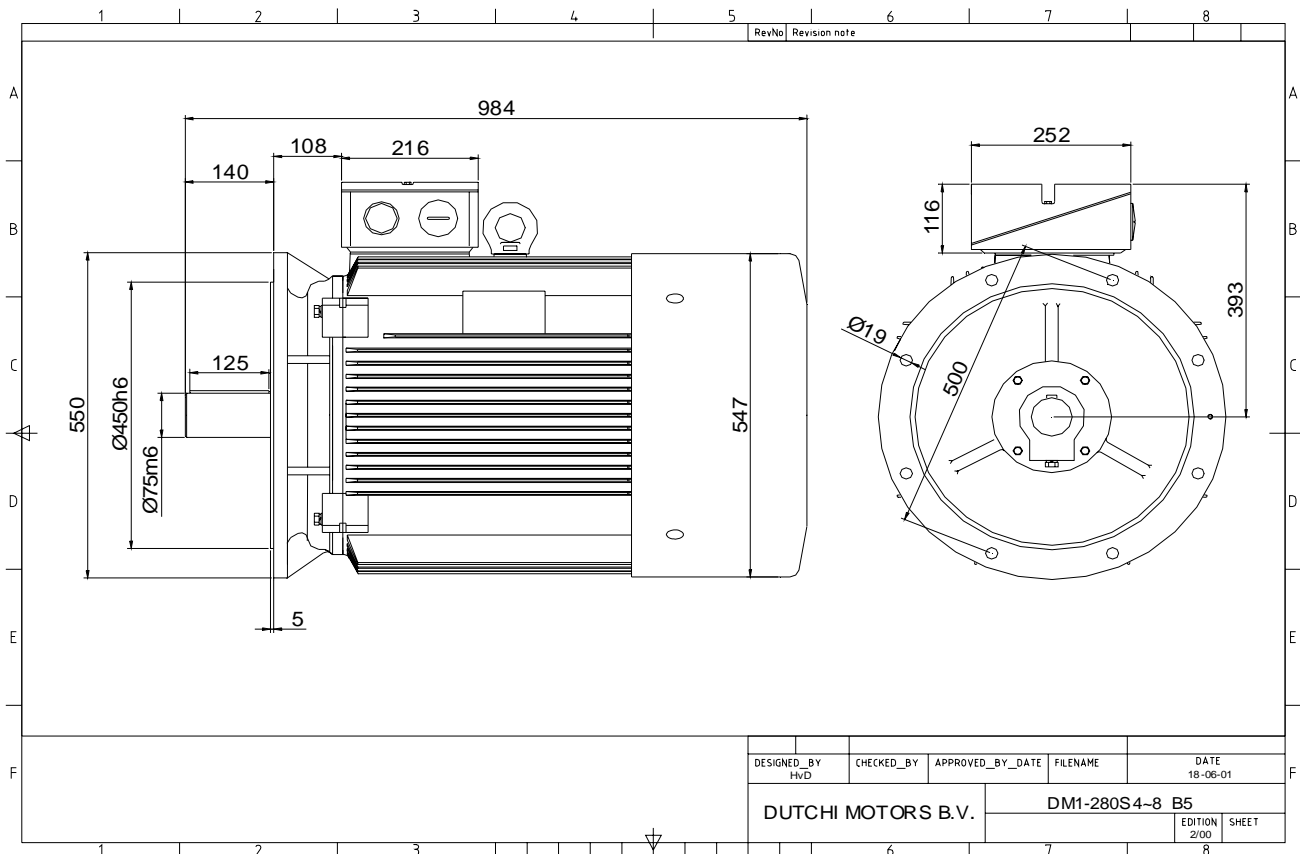

Specification	IEC 60034-1
Manufacturer	Dutchi Motors B.V.
Motor type	DM1-HE 280S4
Rated power	75,0 kW S1 duty
Speed	1486 r.p.m
Voltage	400 / 690 V
Frequency	50 Hz
Connection	Δ / Y
Amps full load	126,5 / 73,0 A
Amps no-load(400V)	33,90 A
Enclosure	IP 55
Insulation Class	F (temp. rise B (80 K))
Max. coolant temp.	40°C
Max. altitude	1.000 mtr, above sea level
Comment	3 x PTC 150°C
Cable entries	2 x M63x1,5 + 1 x M20x1,5 (ptc)
Feature	Cast-iron motor
Weight	kg
Catalog no.	11234A75DH
Warranty	12~18 months

Efficiency class	EFF 1			
Load data	100%	75%	50%	25%
Efficiency	95,0	95,1	94,5	91,4 %
Power factor	0,90	0,88	0,83	0,68
Sound pressure level (1m)				70,4 dB(A)
Resistance R20 (open)				0,063 Ω
Resistance R20	Δ			0,042 Ω
Full load torque				482 Nm
DOL Starting torque vs FL torque				2,05
DOL Pull up torque vs FL torque				1,41
DOL Pull out torque vs FL torque				3,35
Star-Delta Starting torque vs FL torque				0,64
Star-Delta Pull up torque vs FL torque				0,44
Star-Delta Pull out torque vs FL torque				1,05
DOL Starting current vs FL current				7,02
Star Delta Starting current vs FL current				2,19
Rotor Inertia				kgm ²
Bearing DE				6317 - C3
Bearing NDE				6317 - C3

WI	Change	date	sign.
Dutchi Motors B.V. P.O. Box 5390 NL-6802 EJ ARNHEM Tel : +31-(0)26 - 3541 600 Fax : +31-(0)26 - 3541 650		Discription Drawing made by :	date 27-04-04
		sign.	HvD
		dutchi.motors@dutchi.nl www.dutchi.com	